



Division of Forensic Sciences Evidence Handbook

Copyright© 2022 by the State of Wisconsin
Department of Justice All rights reserved.

May not be reproduced in part or in whole in any form
without the express permission of the Department of
Justice.

First Edition – 1968
Second Edition – 1973
Third Edition – 1981
Fourth Edition – 1987
Fifth Edition – 1993
Sixth Edition – 2001
Seventh Edition – 2003
Eighth Edition – 2009
Ninth Edition – 2017
Commemorative Tenth Edition – 2021 (title change
from Physical Evidence Handbook to Evidence
Handbook)

Published in the United States of America

Table of Contents

Preface	4
Chapter 1	17
Chapter 2	34
Chapter 3	46
Chapter 4	68
Chapter 5	73
Chapter 6	84
Chapter 7	86
Chapter 8	101
Chapter 9	110
Chapter 10	117
Chapter 11	148
Chapter 12	181
Chapter 13	185
Chapter 14	190
Chapter 15	195
Chapter 16	198
Chapter 17	204
Chapter 18	208
Chapter 19	210
Chapter 20	212
Chapter 21	215
Chapter 22	218
Chapter 23	228
Chapter 24	241
Chapter 25	252

Preface

The Forensic Science community continues the trend of change, and the Evidence Handbook updates from the last revision of the Physical Evidence Handbook reflect the changes in the field of Forensic Science. The release of the National Academy of Sciences report *Strengthening Forensic Science in the United States: A Path Forward*, resulted in the emergence of the Organization of Scientific Area Committees (OSAC) now made up of seven Scientific Area Committees (SACs) consisting of 22 discipline-specific subcommittees that operate under the core principles of balance, consensus, harmonization and openness, and are coordinated with facilitated development by the National Institute of Standards and Technology (NIST). The Wisconsin State Crime Laboratories (WSCL) support the consensus-based standards of OSAC. While the scope of this handbook focuses on the evidence of forensic science or the application of various sciences to law, discipline-specific evidence submissions are handled in consideration to the policies and procedures that incorporate applied guidelines outlined by OSAC standards.

The need for proper recognition, documentation, collection, and preservation of evidence is apparent to all who are involved in the criminal justice system. Evidence can lead directly or indirectly to the resolution of a crime. Charging and prosecuting decisions may be affected by the quality of the evidence supporting the case. The United States and Wisconsin Supreme Court decisions have placed great emphasis upon evidence in criminal cases.

As an important link between collection and court presentation of submitted evidence, the service provided by the Wisconsin State Crime Laboratories allow most agencies within the state the opportunity to

rely on quality forensic examinations, reporting and testimony. The practical reality is that some materials submitted to the Laboratories sometime prove inadequate for proper analysis. Improper collection or packaging methods destroy valuable evidence. It is unrealistic to expect that all submitters will know how to collect evidence in the manner required by the Laboratories, however, submitters should at least have general knowledge of proper techniques as guidance.

This handbook is offered in the belief that increased knowledge leads to understanding and that understanding leads to improved practices. It was written to provide information regarding WSCL requirements surrounding the collection and preservation of evidence. This handbook, however, is not intended to be a comprehensive treatment of all the factors involved in a criminal investigation.

Because the laws and legal precedents concerning collection of evidence are subject to change, it is impossible to give specific, up-to-date information on acceptable procedures. Therefore, it is imperative that during an investigation, close liaison is maintained between the prosecutor's office and persons responsible for the collection of evidence.

The Quality Assurance Bureau and other staff of the Wisconsin State Crime Laboratories have revised and updated this 10th edition of the Handbook with the intention that it will continue to be of great value to those who use it.

Gratitude and acknowledgement are expressed to laboratory staff for their many contributions to the work and to the Wisconsin State Crime Laboratories colleagues in other Divisions of the Department of Justice who have assisted in seeing this revision completed. Special acknowledgement is made to WSCL

Technical Leaders, Justice Supervisors, the Creative Team, and Laboratory management.

Introduction

Wisconsin State Crime Laboratories

The first Wisconsin State Crime Laboratory, located in Madison, was created by the Legislature in 1947. A second laboratory opened in the Milwaukee area in 1975. The Wausau Laboratory opened for business in 1991. Since the last edition of this handbook, the single State Crime Laboratory Bureau became its own Division of Forensic Sciences referred to as the Wisconsin State Crime Laboratories within the Department of Justice and continues to provide technical assistance in criminal matters when requested by authorized parties.



Mission: *To promote excellence in analysis, training service to the community and our organization with integrity and uncompromising quality.*

Vision: *To search for the truth through science and to lead and shape the advancement of forensic science.*

Contact information for the three crime laboratories within the Division of Forensic Sciences, Department of Justice is as follows:

State Crime Laboratory-Madison

4626 University Avenue, Madison, WI 53705-2174
Phone: (608) 266-2031, Fax: (608) 267-1303

State Crime Laboratory-Milwaukee

1578 South 11th Street, Milwaukee, WI 53204-2860
Phone: (414) 382-7500, Fax: (414) 382-7507

State Crime Laboratory-Wausau

7100 Stewart Avenue, Wausau, WI 54401-8410
Phone: (715) 845-8626, Fax: (715) 848-5833

The service map provides guidance on the nearest and targeted lab to assist agency needs.

Laboratory Service Areas

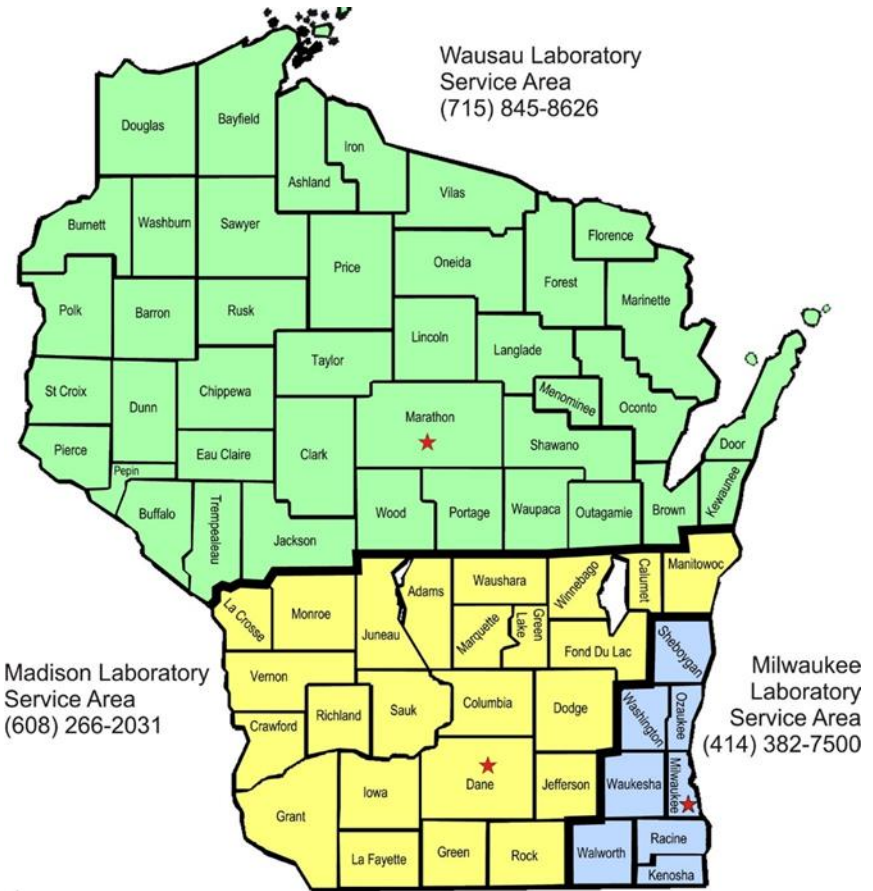

Forensic Analysis Units

Scientific analysis of evidence is conducted at the Laboratories by specialized units grouped into three sections.

Areas of Analysis:

Chemistry	Controlled Substances	Analyzes for presence (or absence) of controlled substances (i.e., cocaine, heroin, methamphetamine, LSD, and THC).
	Toxicology	Analyzes bodily specimens for presence of harmful substances or for criminally unlawful substances. Includes unknown causes of death and felony alcohols.
	Trace	Analyzes a broad spectrum of physical evidence including paint, glass, fibers, fire debris, explosives, plastics, lubricants, household and industrial chemicals, building materials, cosmetics, tapes, ropes and cordage, metals.
Criminalistics	Firearms/ Toolmarks	Examines firearms and tool marks; NIBIN entry of guns and unsolved cases; gunpowder pattern interpretation and serial numbers restoration.

	Latent Prints & Footwear	Examine for the presence of friction ridge and footwear impressions; compare impressions to known standards; conduct AFIS & FW investigative lead searches.
	Forensic Imaging	Conducts image and video analysis and provides imaging support for other analytical units.
	Crime Scene Response	Respond to law enforcement agency calls for major crime scenes assistance (homicides and autopsies).
	AFIS Specialists	Operate State's Automated Fingerprint Identification System (AFIS); provide identification information to all law enforcement agencies in Wisconsin. The central repository for fingerprint State arrestee identification records.
DNA	DNA Analysis	Examine evidence for biological materials, develop DNA profiles and compare these profiles to persons of interest.

	DNA Databank	Maintain database of forensic evidence samples for comparisons against convicted offender and arrestee samples. Maintenance includes thorough examination of samples for deposit.
--	--------------	---

The Madison and Milwaukee laboratories are full-service facilities while the Wausau laboratory supports drug analysis, the examination of fingerprints/footwear, imaging, and crime scene response.

Digital Forensic and/or Human Trafficking Evidence

The Digital Forensics Unit (DFU) and the Human Trafficking Bureau of the Wisconsin Department of Justice are in the Division of Criminal Investigation. The DFU conducts forensic analysis of computer/digital evidence by extracting information from digital devices that can be valuable components of an investigation. Call the DCI general contact number about human trafficking information or evidence and/or questions involving digital evidence: Wisconsin Department of Justice, Division of Criminal Investigation (608)266-1671.

Procedure for Requesting Aid

The WSCL is authorized to participate in a criminal investigation only at the request of authorized governmental officials (see table). Services are available to the defendant in a felony action upon his or her request and with the approval of the presiding judge (Wis.Stat. §165. 79(1)). The WSCL also cooperates with federal and other state agencies.

Governmental Officials Authorized to Request Laboratory Assistance

[Wis. Stat. §165.75(3)(b)]

Sheriff	Chief of Police
Coroner	Attorney General
Medical Examiner	Governor
District Attorney	Head of any State Agency

Fig. Intro-1 Authorized submitters to the Laboratory.

The head of any Wisconsin State Department may request investigations. In such cases, the services provided by the WSCL shall be limited to the fields of health, welfare, and law enforcement responsibility which has by statute been vested in the particular state department. Examples of such state departments include the Department of Natural Resources, the Department of Agriculture, the Department of Health and Family Services, and others.

When Laboratory assistance is desired, it is suggested that the district attorney of the appropriate county be advised that an investigation is being undertaken and that Laboratory services are needed and requested.

The Department is also authorized by statute to decline to provide Laboratory service in any matter not involving a potential felony charge.

Services Not Offered

The Laboratory no longer offers analytical services for bloodstain pattern analysis, tire impression evidence, questioned documents and gunshot residue. Refer to the FBI for assistance. Guidance and procedures for collecting, preserving, packaging, and shipping evidence to the FBI may be found in the FBI Handbook of Forensic Services at <https://www.fbi.gov/file-repository/handbook-of-forensic-services-pdf.pdf/view>. The Laboratory does not offer bite mark examination.

Technical Support

The Laboratory is available for consultation. If in doubt, law enforcement officials are urged to communicate with laboratory staff about particular problems confronting them regarding evidence in their investigation. The Laboratories are open Monday through Friday, 7:45 AM to 4:30 PM, except holidays. Forensic Scientists are available 24 hours a day to answer questions concerning evidence recognition, collection, and preservation. Contact the laboratory in your service area. If unable to reach the Crime Scene Response Team or a Forensic Scientist after business hours, contact the Time Control Center at (608) 266-7633.

Field Services

Field services are provided by the Office of Crime Scene Response when requested by an authorized law enforcement official. Processing crime scenes of major offenses with mobile units equipped to aid in the recognition, documentation, recovery, and preservation of materials that may have evidentiary value.

Laboratory personnel are not vested with power of arrest. Suitable law enforcement personnel must be present in the field to protect and assist Laboratory personnel when processing scenes for evidence.

The Laboratory provides field services in the following areas:

Evidence Collection	Upon request, forensic scientists will respond to death investigations to assist with evidence/scene processing.
Clan Laboratory Chemist	Support with clandestine laboratories, in conjunction with the Division of Criminal Investigation (DCI) is available.
Autopsy	When requested, Crime Scene Response Units will assist at autopsies.

It is important that the crime scene is well protected and kept secured by law enforcement personnel when field assistance is requested. The requesting agency should assign the officer most familiar with the case to assume responsibility for the investigation. During the examination and processing of the crime scene, the officer who is assigned the case and other officers who have attended death investigation school, evidence technician and/or crime scene processing courses should be made available to assist Laboratory personnel.

CRIME SCENE RESPONSE (CSR) SERVICE AREA

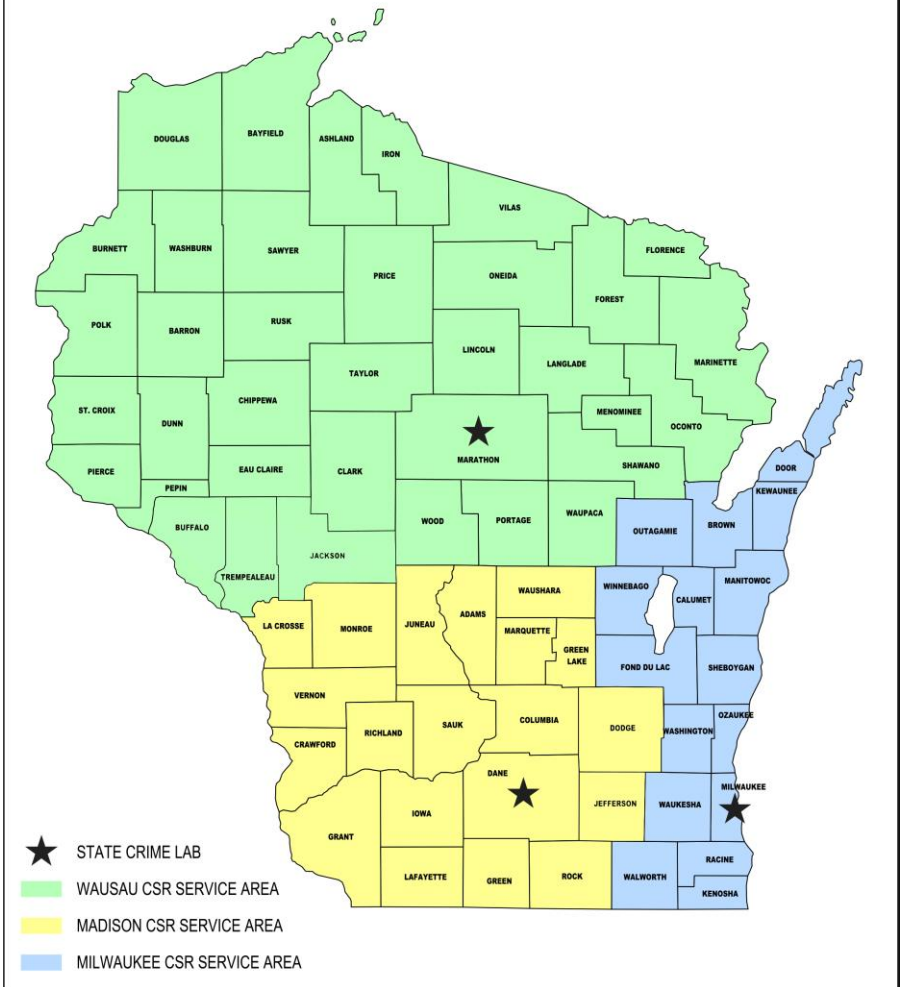

Figure Intro-2 A map of Wisconsin indicating the Crime Scene Response service areas separated by Wausau CSR area, Madison CSR area, and Milwaukee CSR area.



Law enforcement agencies requesting assistance for crime scene investigations may contact the Laboratory at the following telephone numbers:

Agencies in the southern 24-county area served by the Madison Laboratory (608) 266-2031 (24-hours a day)

Agencies in the southeastern 8 county area served by the Milwaukee Laboratory should contact the Milwaukee Laboratory (414) 382-7500 (24-hours a day)

Agencies in the northern 40-county area served by the Wausau Laboratory (715) 845-8626 (24-hours a day)



Fig. Intro-3 Crime Scene Response Units

Chapter 1

Evidence Integrity

In any criminal investigation, the validity of information derived from the examination of the evidence depends entirely upon the care with which the evidence has been protected from contamination, degradation, or deleterious change. In other words, if the evidence has been improperly collected, handled, or stored, its value may be reduced, and no amount of laboratory work will be of assistance. Therefore, it is important that items of evidence be collected, handled, and stored in a way that will ensure their integrity. In doing so, the likelihood is increased that useful information can be extracted from the examination and that the item will be considered admissible in court proceedings.

Refer to Chapter 2 for crime scene processing

When submitting evidence to the Laboratory, determine the most probative pieces of evidence to prioritize analysis. Evidence Submission Guidelines are available to submitters for assistance in prioritizing evidence for analysis. Laboratory staff are available if further assistance is required.

I. Collection of Evidence

It is important to properly collect, seal, and identify items of evidence and maintain a proper chain of custody for two reasons. First, you must be able to prove that the item introduced in court is the same item that was collected at the scene. Second, you must ensure that the item is not altered or contaminated between the time it was collected and the time it was examined forensically or entered as evidence. These objectives are best achieved by proper packaging and

sealing of evidence and maintaining a proper chain of custody.

Packaging

Packaging materials should protect the item from contamination, tampering, or alteration. Packaging materials should not cause deterioration. For instance, articles of clothing should not be packaged in material that traps moisture. Items that might contain residual moisture should be packaged using a porous material that allows moisture to pass through, such as paper or cardboard. (Note: items for DNA examination should always be packaged in porous material, even if they appear dry.)

Unless an item of evidence is a liquid sample, items that are wet should be allowed to dry before being packaged and then packaged in paper or cardboard. There are occasions when a vapor-tight container (metal can) is required. One example is when flammable liquid vapors are sought in fire debris.

Another way that packaging could contribute to deterioration is through abrading the surface of the item, thereby removing surface deposits. For instance, fingerprints can be obliterated by friction between the container and the item. Also, markings on lead bullets can be altered if packaged improperly.

Only new, unused materials should be used to package evidence. If the packaging has been previously used, trace evidence can be imparted to the item, negating the value of some examinations. Common packaging materials include paper, cardboard, plastic, metal cans, and glass.

Porous Material. Paper goods are porous and is appropriate packaging for many types of items, it allows water vapor to escape. As a result, it is the

packaging of choice for items which may contain residual moisture (unless it is important that the vapors be trapped). Clothing and other cloth items which are to be examined for DNA evidence should always be packaged in paper; moisture can lead to the destruction of DNA samples. Plant materials, such as marijuana or mushrooms which are confiscated fresh, should be thoroughly dried before submission to the Laboratory. When stored in plastic, plant material will mold, or, with enough time elapsed, may decompose (*see Chapter 24 - Controlled Substances*).

Paper is also more appropriate than plastic for very small samples such as hairs, paint chips, and other small items. Surface treatments and static electricity may cause trace evidence to cling to plastic. This is not as great a problem with paper. The primary concern when using paper with trace samples is that the paper is securely folded and sealed so that the sample cannot escape through an opening.

Bags. Paper bags come in many sizes. Bags are a good choice for bulky items. Choose a bag that is sized to the item -- don't use a full-size grocery bag to collect a wristwatch or a paint chip. Bags may leak at the seams and may not be suitable for powder evidence unless all possible openings are taped.

Envelopes. Envelopes also come in a variety of sizes. "Coin envelopes" are good for small samples. Letter-size envelopes work well for many items. Large envelopes can be useful for larger moderately heavy items. Some envelopes designed to hold evidence are constructed with a clear acetate window which allows the contents to be viewed while retaining the breathability of paper. Like paper bags, envelopes may leak at the seams and may not be suitable for small evidence unless the seams are taped.



Fig. 1-2 Examples of various cardboard boxes including slide boxes, swab boxes, and a box for securing weapons.

Glass vials and jars. Glass vials and jars are useful for liquid samples: blood, alcohol, flammable liquids, water and so forth. Blood samples should be collected by following instructions contained in the Handbook chapters on Toxicology, DNA samples, and Autopsy. The vial or jar must have a tight-fitting top and must be protected from breakage once collected



Fig. 1-3 Glass vials are available from hospital and scientific supply outlets. Smaller glass vials can be packaged within Nalgene bottles for protection. Use a clean, new pipette to transfer liquids to glass vials. In the case of glass pipettes, use a rubber bulb or other device designed for the purpose of providing suction. Never use your mouth--the practice is dangerous and may contaminate the sample.

Plastic. Plastic has several obvious advantages: it has great strength for its weight and transparent plastic allows inspection of the contents. However, there are several disadvantages which must be recognized. First, water vapor does not freely pass-through plastic. Most evidence is adversely affected by prolonged exposure to water: steel will rust, cardboard or paper may decompose, biological materials (blood and semen stains) are destroyed, and natural clothing materials (leather, wool, cotton) can mold and degrade. Some gaseous materials and vapors, depending on the plastic's moisture vapor transport rate (MVTR), can pass through semipermeable plastic and therefore may allow sought-after samples to escape. See the section, "Metal cans," for further details. Plastic is acceptable for items that you are certain are dry, especially plastics, paper, drug powders and tablets, etc.

Plastic sharps containers are available in a variety of sizes. Hypodermic needles must be packaged in a sharps container before submission to the Laboratory. Knives must be packaged in a sharps container or secured within a cardboard box. Consideration should be taken when deciding what packaging to use. If DNA testing is requested, secure the knife in a cardboard box and not a plastic sharps container.



Fig. 1-4 Examples of plastic sharps containers. Do not package knives in plastic containers if DNA testing is requested.

Metal cans. New, clean, unlined cans are ideal for storing biological samples that could evaporate. The most common examples are flammable liquid accelerants found in fire debris (e.g., gasoline, charcoal lighter fluid, etc.). A used can is not acceptable; paints contain solvents that are similar to accelerants. For the same reason, you should never reuse any evidence packaging materials, including cans. As indicated above, plastic allows hydrocarbon vapors to escape. Plastic may also be attacked and destroyed by high concentrations of vapors. **For these reasons, volatile samples should only be stored in metal and never in plastic.**

This general discussion is intended to give guidance in situations where specific instructions are not provided in the Handbook. Consult chapters dealing with specific types of cases or evidence and if provided, follow instructions.

Sealing

Evidence received by the Laboratory must be properly sealed. A proper seal provides proof that an item has not been accessed and therefore could not have been altered or contaminated during storage or transport. Nothing can be added or removed from properly sealed package. The primary requisite of a good seal is that if it is tampered with, the tampering can be detected. There are many recognized sealing methods, and a number are discussed below.

Methods of sealing evidence include heat sealing in plastic, tapes, tamper-proof tapes, tamper-proof adhesive strips, or a combination of these methods.

Tape. Cellophane or cloth tape can provide a tamper-evident seal on some surfaces. However, tape on plastic does not provide an acceptable seal because it can be easily removed and replaced. The security of

this method is improved by use of tapes with organizational names printed on them (thereby limiting the number of persons who could reseal the item). Use an indelible pen to **write your initials across the junction of the tape and the container.** If disturbed, it will be nearly impossible to reposition the tape so that it precisely matches.



Fig. 1-5 Close the opening of the container by folding over the opening more than once. Use an indelible pen to write the sealer's initials and date across the junction of the tape with the container.

Tamper-evident tapes. Tamper-evident tapes are destroyed by efforts to remove them. Traditionally, the security feature was created by a combination of a tenacious adhesive and a low tensile strength backing. Some new tapes change color or have words develop when disturbed. The tapes come both in long rolls and in short, individual strips.



Fig. 1-6 Tamper-evident tape is available from several suppliers and in multiple colors. Your agency's name can be added to the tape as an additional identifier. These tapes are advertised as providing tamper-evident seals on all surfaces. Some brands of tape can be removed from plastic bags without evidence of tampering. Always check for permanence on an identical test object before using a particular tape. If the brand of tape or packaging is changed, retest.

One advantage of tamper-proof tapes is that they are designed to shred or tear when pulled or stressed. This advantage is also a potential disadvantage, if a mechanically strong joint is required. Unless somehow reinforced, the tape may spontaneously shred if stressed. When the tape joint may be strained, use another method to secure the joint and then use tamper-evident tape across the joint. Some tamper-evident tapes will not adhere under cold conditions.



Fig. 1-7 Use an indelible pen to write the sealer's initials and date across the tape. Make sure the sides as well as the bottom of the flap of the envelope are covered with tape to prevent anything from being added to or escaping from the envelope. The examples illustrate the flap folded inside or outside the envelope and taped with one or multiple strips of evidence tape. Always check the manufacturer's seal on the packaging to ensure that it is adequate.

Tamper-evident adhesive strip. Tamper-evident adhesive strips attached to plastic bags are a quick and easy method of sealing plastic bags. Remove the plastic protective cover from the adhesive and either squeeze the sides of the plastic bag together or on some bags fold the plastic flap over the adhesive strip and squeeze together. **Write your initials on the plastic bag directly over the adhesive seal.** Any attempt to disturb the seal results in distortion of the plastic bag and/or the initials.

Staples. **Stapling, by itself, is not an acceptable method to seal evidence.** However, it can be used in conjunction with other sealing materials. Be aware, exposed staples can present a sharps hazard. **If staples are used, they must be covered by tape.**



Fig. 1-8 Use an indelible pen to write the sealer's initials and date on the sealed evidence.

Heat sealing. The heat-sealing method partially melts the plastic packaging and fuses it together. Some sealers emboss an identifiable mark into the seal. Use an indelible marker to write your initials and date across the seal. These markings provide evidence that the package was not opened and resealed.



Fig. 1-9 Several different types of plastics can be used with heat sealers, but each requires a different time/temperature combination. Make sure that you sufficiently heat the plastic to ensure the halves are fused together. Also pictured are commercial heat sealers. The heat sealer pictured embosses an identifiable mark into the seal.

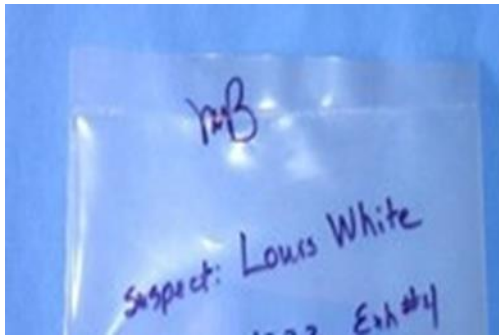

Fig. 1-10 Use an indelible pen to write your initials and date across the heat seal to authenticate it.

Chain of Custody

The chain of custody is a record that documents every person that had custody and control of an item from the time it was collected until its introduction into court. It allows the courts to question all persons who

possessed an item regarding their handling procedures and the actions they took.

The importance of a properly documented chain of custody cannot be overemphasized. The chain is often closely scrutinized. Evidence is challenged and sometimes rejected because of improper handling or documentation. Thus, it is extremely important that proper methods be used in collecting, preserving, and documenting evidence.

The chain should be no longer than necessary. Ideally, it should include only:

1. The investigator who recovers the evidence.
2. The departmental evidence custodian (in cases when the item is not immediately transported to the Laboratory by the recovering investigator).
3. The person who transports it to the Laboratory (if possible, one of the two preceding individuals).
4. The person (normally a Laboratory Technician) who receives the evidence at the Laboratory.
5. The Laboratory scientist who examines the evidence.
6. The person that retrieves it from the Laboratory (if possible, one of the first two individuals).

Transmittal of Criminal Evidence

When submitting a new case or additional items for a case already submitted, a Transmittal of Criminal Evidence must accompany the evidence (Fig. 1-11). This form supplies important details that are needed for Crime Laboratory record management. It also ensures that reports of analysis will be associated with the correct offense. If your agency does not have this form or if you have any questions about proper completion, contact the Laboratory in your service area. An electronic version of the Transmittal of Criminal Evidence is available upon request from the Laboratory

in your service area and can be found on the Wisconsin law enforcement website <https://wilenet.widj.gov/>

Each offense should be submitted as a separate case. For instance, if fingerprints were found at three businesses burglarized on the same night in the same strip mall, each burglary could result in a separate criminal count. Therefore, each incident should be submitted on a separate form. In a drug case, if more than one buy/deal occurs involving the same suspect on the same day, the Laboratory considers **each** buy/deal a **separate** case which must be submitted on **separate** transmittals.

Make sure all entries are legibly recorded, typed is preferred. If there are special instructions, note them on the Transmittal or include them in a letter in the same envelope.

Information to be supplied includes:

- A. Submitting Agency: Name of agency submitting case (Police Department, Sheriff's Office, MEG Unit, etc.)
- B. Submitting Agency Case Number: Identical agency case number as shown on the evidence.
- C. City of Agency: Municipality where agency is located.
- D. County of Agency: County where agency is located.
- E. Date Transmitted: Date case is mailed or transported to Lab.
- F. Offense Committed in City/Town/Village (if known).
- G. County of Offense: List only one county.
- H. Offense Date: Only one incident per transmittal. Must be one specific date, not a general time frame.
- I. Criminal Offense: List all charge(s). Be specific. In drug cases, this is typically possession,

possession with intent, delivery, manufacturing, etc. In cases such as arson, burglary, or theft, be sure to indicate the type of property burned, burglarized, or stolen.

- J. Trial Date: Date of jury trial, if known.
- K. Person(s): Victim(s) of the crime and Suspect(s) if known. In drug cases, there are usually no victims. In the case of multiple burglaries, each burglary is a separate case even though the same suspect(s) may be involved. If a business is involved, include name of business, owner, and any employees involved; list the cashier in armed robbery, etc.
- L. Sex: Sex of all persons involved. This information is necessary in sexual assault cases for both victim and suspect.
- M. Date of Birth: Date of birth of all persons involved.
- N. Agency Exhibit Number: If submitting agency has an exhibit number, item number, or inventory number for the item of evidence, it may be listed here and must match the number shown on the evidence.
- O. Number of Items: Number of pieces of evidence being submitted under your item number or inventory number.
- P. Item Description and Source: Brief description of evidence and the analysis requested.
- Q. Requested Analysis: The abbreviation for the analysis to be performed.
- R. Submitting Officer Information: Full name and phone number of officer submitting case.
- S. Case Officer Information: Full name, email address, and phone number of Case Officer.

If evidence is mailed or shipped to the Laboratory, place the Transmittal in an envelope and attach to the outside of the package.

Packaging Checklist

Before shipping evidence ask yourself:

- Has evidence been properly collected, preserved, and sealed for submission to the Laboratory (heat seals marked with the sealer's initials, all tape seals marked with the sealer's initials across the junction of the tape ends?)
- Has evidence, to include fingerprint cards, been properly sealed?
- Has evidence been properly packaged for shipping to the Laboratory?
- Has the Transmittal of Criminal Evidence been properly completed?
- Has the Transmittal of Criminal Evidence been put in an envelope attached to the **outside** of the package?

Chapter 2

Crime Scene Response

The Office of Crime Scene Response will assist authorized agencies in the processing of crime scenes.

I. Preserving the Crime Scene

The first officer at the scene of a crime has several immediate responsibilities. Among these duties is preserving the integrity of the scene by preventing the destruction of potential evidence that may lead to the resolution of the crime. To accomplish this responsibility, the first officer at the scene should consider the following:

- A. Secure the scene.
- B. As you near the scene, take note of persons and vehicles in the general area.
- C. Attempt to obtain identification of any persons leaving the scene.
- D. Limit access to the scene. Determine scene perimeter.
- E. Note your route through a scene as you “clear” the scene.
- F. Remove or isolate persons present at the scene, so that they do not purposely or inadvertently alter or destroy evidence.
- G. Every attempt should be made to exclude official “sightseers” by explaining the potential consequences of disturbing the scene.
- H. Maintain a crime scene log in which the name, department, arrival, and departure of each person at the scene is recorded.
- I. Use a camera to document the scene as it was initially found.
- J. Record any changes to the scene by your actions or those of emergency personnel.

- K. Make note of the following but do not move or pick up anything:
 - 1. Doors and windows - opened, closed, locked?
 - 2. Lights, TV's or radios - on or off? Which ones?
 - 3. Odors (cleaning solutions, cigarette smoke, perfume, etc.) in the air?
 - 4. Items out of place?
 - 5. Condition of body?
- L. Attempt to "freeze" the scene as closely as possible to the condition in which it was found to minimize the destruction of evidence.
 - 1. Protect the perpetrator's suspected routes of entry and exit. If possible, use another entrance to the scene to avoid destroying possible latent footwear and fingerprint impressions.
 - 2. Protect evidence (such as footwear and tire impressions, biological, and trace evidence) from inclement weather.
 - 3. Wear gloves and, if necessary, shoe covers when entering the scene. (Shoe covers should be worn at scenes where biological and trace evidence and latent footwear impressions may be important.)
- M. Collect victim/suspect clothing including footwear. If the victim's clothing is removed at the scene by emergency personnel, advise them not to cut through holes in the clothing.
- N. Record any observations of the suspect(s). Any injuries? Any bloodstains on hands or clothing? Condition?

II. Processing the Crime Scene

Processing of a crime scene should begin with an assessment. This assessment will help to formulate a systematic plan for the recognition, collection, and preservation of evidence at the scene. Conduct a

walkthrough of the scene with an officer well informed of any actions that have occurred at the scene. As you conduct this assessment note the following:

- Potential evidence along the perpetrator's suspected routes of entry and exit.
- Is there evidence of forced entry? Toolmark impressions?
- What items have been disturbed or are out of place? Is there evidence of a struggle? Ransacking?
- Any potential bloodstains on walls, floors, or items.
- Possible weapon. Firearm? Knife? Blunt object?
- Footwear or fingerprint impressions in dust on hard surfaces. Use a flashlight with oblique lighting to reveal this evidence.
- What areas should be processed first to limit loss due to inclement weather or chance of contamination?
- What will need to be photographed? Sketched? Videotaped?
- How the search should be conducted.
- What evidence collection kits are needed? What additional resources?

After the initial assessment, processing of the crime scene can begin. This processing includes note taking, photography and video recording, crime scene diagrams (Chapter 5) and evidence collection.

This handbook includes collection methods of various items of evidence that may be encountered at the scene. **If an investigator is uncertain as to how to collect a certain piece of evidence, contact the Crime Laboratory for specific instructions.**

When processing the scene, appropriate personal protective equipment (PPE) is worn. Practice universal precautions (assume all biological samples are

contagious). Change gloves often especially between items collected for DNA evidence. Wear shoe covers at scenes to protect yourself and the scene.

If the crime scene involves a death investigation, do not remove the victim(s) until the route of removal and the area around the body have been processed to avoid contamination or destruction of evidence. Bag the victim's hands to preserve evidence that may be trapped under the victim's fingernails. The body should be wrapped in a new sheet and placed in a sealed body bag. An autopsy of a suspicious death should be conducted by a qualified forensic pathologist.

III. General Crime Scene Photography

Camera Settings:

Exposure Mode: Manual "M"

File Format: JPEG Large/Fine

ISO: 400 (100 for bright sun)

Aperture: f/8 to f/16

Shutter Speed: As appropriate for meter reading. A tri-pod is essential for longer shutter speeds. Avoid $<1/60^{\text{th}}$ for handheld.

Lens Stabilizer: "OFF" if camera is on a tri-pod, "ON" if camera is being handheld.

Lens: Zoom 24-105mm, focal length between 30-50mm for most accurate human perspective.

Focus: Automatic or manual. Focus as appropriate for items in scene.

Flash: As needed, ETTL or manual (power down as needed).

Summary: Crime Scenes vary from scene to scene, and not all scenes can be photographed in the same manner from one to the next. Scenes at night or in low-light situations may require additional light and/or longer shutter speeds. A tripod is best whenever possible as it limits camera shake and allows the photographer to step back from the camera to better assess the camera settings, lighting, and scene surroundings. Evidence should always be photographed in-situ and should not be moved or collected until photography is completed.

Evidence should be photographed in the location and in the condition found. Items of evidence should also be re-photographed following the placement of unique evidence markers. Every effort should be made not to include yourself, other persons or objects not part of the scene in the photographs.

Procedure: Determine a photographic starting point and progressively take photographs working your way into the scene. Photographs should maintain continuity between each other to present a "picture story" of the scene when possible. The photo log can aid in further describing occurrences where the picture story may be interrupted. For example: The photographer is outside of a scene photographing a house when asked to come inside to photograph the location of a cell phone prior to collection.

- Photograph rooms from each corner with a minimum of four views. Additional photographs may be required of ceilings, floors, doorways or hallways if not covered in the four minimum views.
- Photograph bodies from all angles (be careful of distortion when photographing from head and feet) and overhead if possible. Do not disturb the body or clothing on the body to take photographs. The body will be further photographed and examined at autopsy.

Scenes should be photographed keeping four basic views in mind:

Overall views: These show general locations, conditions and surroundings. These should be done at photographer's eye level unless duplicating a witness's point of view.

A large outdoor scene, a scene involving several buildings, or a route used may require aerial

photographs. All scenes should have 360° overall views looking toward the scene and looking away from the scene. If possible, include identifiers like street numbers, fire numbers, permanent reference points, etc. Structures should have all sides, surrounding areas and adjacent buildings photographed.

Interior overall views using the minimum four corner technique should be produced of all rooms connected with the scene.

Medium (or Intermediate) views: These show a significant segment of the scene that has been previously recorded in the overall views. An example would be a body lying in the middle of the room. An overall view would show where the body was in relation to the room. A medium view would focus attention to the particulars of that body to give details like type of clothing, position of extremities, items close to the body, etc.

Close-up views: Are used to specifically show position and detail. This would include items such as a gun in relation to the hand, ejected cartridge cases, a bullet lodged in wall, ligatures, gags, bindings, entry damage to door jam, etc. Close-ups of all evidence should be accomplished before collection, measuring and sketching take place.

Specific Evidence views: These are detailed photographs documenting items of evidentiary value. Some examples include footwear/tire impressions, fingerprints, footprints, processed fingerprints before lifting, tool and pry marks, fabric impressions, bite marks, serial numbers, etc.



Overall view of area in a scene



Medium view of area in a scene



Close up view of item in scene



Specific evidence view

Video

Include an audio slate at the beginning (see Section II). If narration or sound is not relevant, the camera's sound recording mode or microphone can be turned off. If a microphone cannot be disabled, care should be taken as to any sounds, or conversations that may be picked up during recording.

Using a very slow panning speed, pan the area to provide an overall view of the entire scene. Complete 360° pans should be made of exteriors of buildings and surrounding area, looking toward the structures and also away from the structures to the surrounding area.

When recording a walk-through of the scene try to avoid “jerky” camera movements, either right to left or up and down. Movement should be as smooth as possible. An alternative to the “walk-through” technique would be to record the scene as if photographing it using the four basic views from a stationary position.

Avoid excessive zooming in on items, only utilize the zoom when necessary and keep your zoom speed slow. Still photography is best for recording individual items and fine details.

When possible, do not include equipment, personnel, or unnecessary elements in your video. Be careful of reflective surfaces, such as mirrors, that may show your reflection or other items in the video.

If light levels are too low where camera will not record or camera gain must be used, consider using an on-camera video light or additional light source. Some cameras have a night mode that will record in infrared, care should be taken in using this mode as it will not accurately record what the human eye is able to see.

See Chapter 3 for additional photographic techniques.

Enhancement of Possible Bloodstains in the Crime Scene

When processing crime scenes where the presence of blood is suspected but is not visible, chemi-luminescent compounds can be used to assist in determining the presence and locations of suspected blood. Luminol and Bluestar® are presumptive tests that react with the heme molecule in blood; however, it also reacts with sodium hypochlorite (i.e. bleach). Positive and negative controls must be tested, and the results documented in the field notes before use at a crime scene.

Luminol and Bluestar® can also be utilized to determine and document whether an attempt to clean up blood at a crime scene had occurred.

Luminol

1. In a spray bottle, mix 25g of sodium carbonate (Na_2CO_3) and 0.5g of luminol with 500mL water until dissolved.
2. Activate the solution by adding 100mL of 3% H_2O_2 .

Test the mixture in a darkened room by spraying on a diluted known bloodstain (a positive control can be prepared by placing a drop of liquid blood on a piece of filter paper and allowing it to air dry thoroughly).

Upon contact with blood, the luminol will cause a luminescent reaction.

Test a negative control (a surface free of blood). A negative control will not give a luminescent reaction.

1. After darkening the area to be examined, spray a fine mist of luminol indirectly on the area to be tested and note any luminescence.

2. Observe area for a period of 30 seconds for the appearance of the dull blue luminescence which signifies a positive result. True positive reactions produce an intense persistent glow remaining for a period greater than 5 seconds. A quick flash of auto-luminescence is not considered a positive test.
3. If possible, record the reaction photographically in a subsequent application. Care should be taken, as excessive applications will dilute the sample.
4. Positive reactions should be followed by a phenolphthalein test.
5. Document observations in the field notes.

Bluestar® Forensic

Prepare reagent in a fine-misting spray bottle according to manufacturer's recommended protocol. Note: Either Bluestar® Forensic Tablets or Bluestar® Forensic Magnum products may be used. Follow the same procedure as that for luminol.

Documentation

- All items shall be photographed before being collected. A scale must be included in the photograph if the photograph is to be used for comparative examinations, e.g. bloodstain patterns;
- A description and the location of each item collected shall appear in the field notes;
- Placement (and measurements) of collected items should be documented for possible inclusion in a scaled crime scene diagram, as needed;
- Results of control testing of reagents must be documented in the field notes.

IV. Bullet Path Reconstruction

Defining a bullet path at a shooting scene is a useful element of crime scene reconstruction. A shooter's position and final bullet location can both be defined by determining the path of a bullet or bullets through a sequence of materials. Such reconstructions are most accurate when a bullet has created both a bullet hole and a subsequent impact site or two or more bullet holes in successive planes of material, e.g., sheet rock on both sides of an interior wall. Inserting rods through the bullet holes (or from bullet hole to impact site) will define a bullet path that can direct the investigator to the shooter's position or to the bullet's likely location (see Figure 2-1). Rods should not be inserted in any bullet hole until documentation and examination of the bullet hole has been completed.

Over short distances, string can be attached to the rods to project the bullet path. This technique is especially useful in reconstructing shootings involving vehicles due to their double-panel construction. However, as the projected bullet path increases in distance from the bullet hole, greater imprecision will be introduced into the reconstruction. For bullet path reconstructions over long distances, a combination of spacer cones, rods and lasers will offer much better precision, especially if meaningful diagramming of the reconstruction is desired.

Unless a bullet passes through a significant thickness of material, a single bullet hole will usually not allow useful reconstruction of the bullet path. However, bullet direction can be determined from through-and-through bullet holes in many materials. For example, the passage of a bullet through metal will create an indentation on the metal surface facing the bullet origin and metal stretch on the surface in the direction away from bullet origin, clearly defining the direction of the bullet through the metal. Bullets that pass-through

auto glass, skull and some plastics will create a crater on the side of the material away from the bullet origin. In other words, the crater opens up in the direction of bullet travel (see Figure 2-2).

Even a portion of a bullet hole in a destructively fractured skull can define the direction of the bullet and subsequently establish exit and entrance. The combination of glass cratering and radial glass fracture in a window can even define the sequence of shots through the window, particularly when working with vehicle shootings.

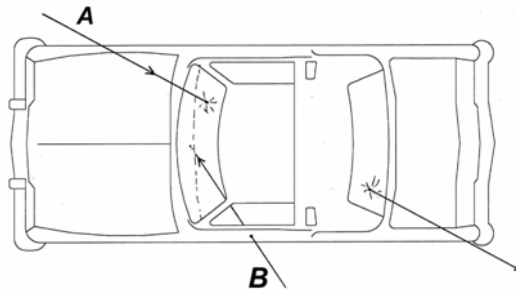

Fig. 2-1 Bullet paths A&B define two shooter locations outside the vehicle. Such diagrams can be included in crime scene notes to aid in shooting reconstructions.

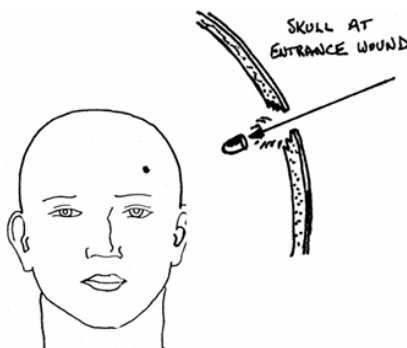

Fig. 2-2 Note the angled or beveled edges of the skull at the entrance bullet hole. The bone surface through which the bullet passed last will present a cratered appearance.

Chapter 3

Forensic Photography

Evidence photography, videography and other evolving 3D imaging techniques are indispensable to the preservation, evaluation, interpretation, and presentation of evidence in court. Evidence photographs, diagrams, videos, and other multimedia must be of consistently high quality as well as fair and accurate representations of the depicted subject matter. The following information provides general guidelines to capture images that will create the best permanent record of the evidence. Many of the techniques or approaches described in this chapter could also be applied to video and other image capture devices. This chapter will address photographic techniques using Digital Single Lens Reflex (DSLR) cameras and Mirrorless Digital Camera systems--the two most commonly available and highest quality capture devices.

I. Crime Laboratory Imaging Services:

The Forensic Imaging Unit (F.I.U.) produces high resolution imagery of physical evidence as well as the enhancement of digital evidence that can be collected and submitted to the Crime Lab (for submission of Video related evidence submissions, see *Chapter 4*). In a controlled laboratory environment, high-resolution images can be created of evidence, where the evidence can further undergo advanced imaging and enhancement techniques that may provide additional visual details that can easily be overlooked or possibly never considered in the first place.

Examples of FIU Imaging services available include:

- High Resolution Imaging
- 3D Imaging and model generation
- Full Spectrum Imaging (Ultraviolet through Infrared)
- Image and Video Enhancement
- Demonstrative Court Exhibits

Please contact the Crime Laboratory if the Forensic Imaging Unit can assist you with your evidence or questions.

II. Photography in the Field

In this section recommendations are provided for photographic equipment, camera settings and techniques. Many situational factors will affect the outcome of a photograph. Available light, environmental conditions, equipment selection and surface substrates are endless in combination, therefore it is recommended to start with the suggested settings and learn to adjust one camera setting at a time to achieve the desired photograph.

III. General Considerations:

Common Camera File Formats

RAW: The Camera RAW file format is a camera's uncompressed file, and the preferred file format for digital images that will be used for comparison purposes (ie: fingerprints, footwear). The two most common RAW file types are Nikon's .NEF file, and Canon's .CR2 file. Each camera manufacturer has their own unique RAW file format which can vary between camera models or change with updated cameras produced from the same manufacturer.

Considerations in using a RAW file formats are:

- RAW files are a proprietary file format, and may not open in standard image viewing programs
- RAW files are usually large in size and will take up more storage space when archived.
- RAW files cannot be overwritten, where are other files such as a JPEG can. This is advantageous in the integrity of a RAW file/image over all others.

JPEG: The JPEG file format is by design, compressed. This file format is suitable for general documentation purposes but is not the preferred format for images that may need to be further analyzed (ie: fingerprints, footwear). Camera's may offer different JPEG settings, the highest quality JPEG should be selected when this format is used.

Many cameras will allow you to simultaneously capture all images in both a RAW and JPEG file format if desired.

“Fill the frame”

This term is a good axiom to remember when photographing evidence or an area of interest within a scene. When framing your shot, be sure to fill the view with the item or area of importance. Having unnecessary space in your image will result in less pixels on the sensor recording the information you are intending to capture.

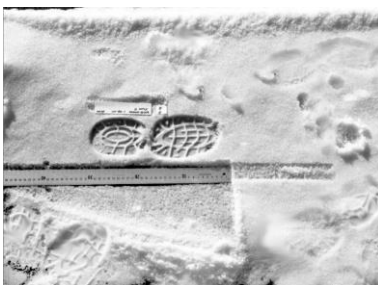

Fig. 3-1 In the example on the left, there is unnecessary space around the subject in the photograph. In the example on the right, the viewfinder

is mostly filled with the subject matter, maximizing the detail able to be captured.

Tripods

A tripod is best whenever possible as it limits camera shake and allows the photographer to step back from the camera to better assess the camera settings, lighting, and scene surroundings. A tripod with an articulating head is ideal for adaptability to various situations.



Scaling Photographs

In criminal investigations, properly scaled photographs are indispensable in the evaluation and interpretation of physical evidence. The location, relative position, appearance, physical size, depth and shape of any object that possesses potential evidentiary value should be photographed, both scaled and unscaled. A forensic L-shaped scale should be used whenever possible. For autopsies, a Forensic ABFO#2 scale is preferred.

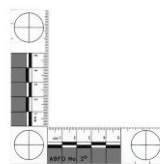

ABFO#2

Scaled Photography Recommendations:

The camera (used in conjunction with a shutter release cable or self-timer) should be placed on a sturdy tripod or camera stand with the back of the camera positioned parallel to the object plane of the evidence with the lens directly over (and perpendicular) to the area being photographed.



The evidence and scale should fill the viewfinder and be in sharp focus. Double check prior to capture and after the image is captured by zooming into the image on the back of the camera.

Scale impression evidence by placing the scale on the

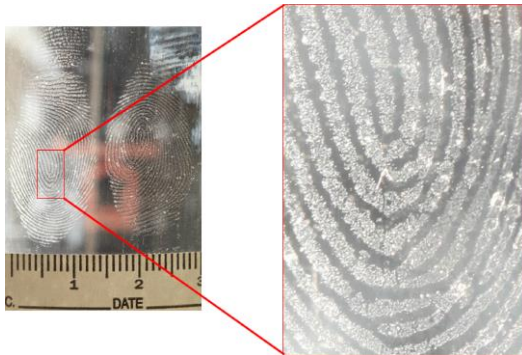

same plane as the impression, being careful not to obscure any detail in the impression.

3D impressions, such as footwear or tire tracks in soil, may require the soil next to the impression to be gently removed to get the scale on the same plane. Be careful not to add or remove anything to or from the area being photographed.

Deep impression evidence, such as footwear impressions, may require scaling at multiple levels depending on the depth and potential future comparative needs of the images.

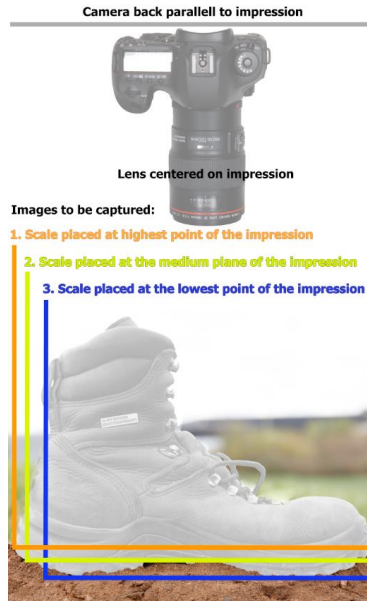

Photo Logs

Generally, departmental policies will dictate what type of information the photographer needs to record. It is suggested that some type of contemporaneous log be maintained of the images that are captured. Photo log information that should be considered include the photographer, date, case number, time started/ended, image number, camera direction and general description of item being photographed. Some of this data may be able to be recorded in the metadata of each image.

When possible, do not combine cases on a camera's memory card, and avoid deleting images once captured. A missing image may be more challenging to

explain than a bad exposure or out-of-focus image. Keep all images as part of the photographic record of the scene and include them in the photo log.

With digital cameras, the date and time are stored in the file's metadata. Therefore, it is important to routinely check the date and time settings on these cameras.

Digital Image Storage

If the original images are saved to a camera card, the original files should be archived per agency policy. It is recommended that original data be archived and protected with fail-safe measures in place. Any viewing or adjustments to an image should always take place on a **copy** produced from the original data.

IV. Photographic Equipment Suggestions:

Equipment Essentials

- (DSLR) Digital Single Lens Reflex Camera or (MILC): Mirrorless Interchangeable-Lens Camera
 - 12 megapixel or greater
 - Ability to capture in RAW+JPEG formats
 - Ability to change lenses
 - Manual exposure modes including "Bulb" setting
 - Hot shoe or sync input (for external flash use)
 - Input for external shutter release
 - Self-Timer
- Storage media cards (with ample storage space 16GB, 32GB)
- Tripod (Sturdy)
 - Versatile head and leg options
 - Center column feature to aide in impression evidence
- Shutter Release with locking feature

- External Flash (Camera manufacturer recommended flash)
- Remote/sync cord for external flash
- Lenses covering Normal to Wide Angle fields of view, and Macro Capabilities
- Continuous Light source (powerful flashlight)
- Extra Batteries
 - For Camera (plus battery charger)
 - For flash unit
 - Flashlights/etc.
 - Camera/Gear Bag
 - Scales/rulers

Equipment Desirables

- Pen Light/Head Lamp light
- Laser/Laser Pointer
- Lens Cloth
- Filters
 - UV/Protective
 - Barrier (i.e.: Red, Green, Blue, Yellow, Orange)
 - Polarizing
 - Magnifying
- Foam core or dark cloth for painting with light (to cover/uncover lens)
- Weather Gear for equipment
- Angle finder/leveling device
- Gray Card (or other white balance tool)

V. Low Light / Available Light Photography

Scenes often intimidate newer photographers and have the photographer believing they will need to add light, such as a flash. Many times, the small amount of light that is present in the scene will suffice. Cameras set to take longer exposures (shutter speed) will collect light in a way that the human eye cannot. The most essential part of this process is utilizing a tripod, or other sturdy device, to limit any camera vibrations or

shake during the long exposure. With a long enough exposure, a scene with only the moon in the sky will look like a photo that was taken at noon.

Camera Settings:

Exposure Mode: Manual “M”

File Format: JPEG Large/Fine

ISO: 400+ (or as high as necessary/possible depending on available light)

Aperture: f/8 as starting point

Shutter Speed: 5 seconds to 30 seconds as a starting point.

Lens Stabilizer: “OFF”

Lens: Zoom 24-105mm, focal length between 30-50mm for most accurate human perspective.

Focus: Manual. May require a flashlight to focus on an object.

Flash: Optional, only as a fill light or if painting in light.

Procedure: Place the camera on a sturdy tripod and attach a shutter release cable. The self-timer feature may also be used in lieu of a shutter release cable. By avoiding pressing the shutter button that is on the camera, the potential for camera shake is reduced considerably. Set the camera to the recommended settings and capture the first

exposure. If the resulting image is too dark, add more time to the shutter being open. Most cameras will go up to a 30 second exposure, some cameras will also allow for even longer exposures by using the Bulb “B” mode. The bulb mode will open the shutter when it is tripped, and it remain open until the shutter depressed. The

ISO and aperture settings can also be utilized to increase the exposure; however, each will have an effect on the resulting image. The higher the ISO, more “noise” may be introduced into the image. The more the aperture is opened up to allow more light in, the shallower the depth of field may be in the resulting image. Additional light can also be added during the exposure using a flash or a flashlight.



Fig. 3-2 Both images depict the same scene using a longer exposure and the streetlight as the main source of light. A vehicle passed through the scene at some point during the exposure in the image on the right. The vehicle’s headlights added light to the house on the left and the trash bin on the right. The red streaks in the image are from the vehicle’s break lights.



Fig. 3-3 In this example, there is a building with a bright light on the left. When only using available light

to illuminate the scene, it causes that area to be overexposed in the image. A second, shorter exposure would help show the building on the left but cause the house on the right to be darker. This can be one of the limitations to only using available light for an exposure.

Camera Settings:

Exposure Mode: Manual “M”

File Format: JPEG

Large/Fine

ISO: 400

Aperture: f/8 (adjust for depth of field)

Shutter Speed: Bulb “B” (as much time as it takes)

Lens Stabilizer: OFF

Lens: Zoom 24-105mm, focal length between 30-50mm for most accurate human perspective.

Focus: Manual. May require a flashlight to focus on an object.

Flash: Manual, Full Power 1/1.

Flashlights also work well

VI. Painting with Light Photography

Summary: Painting with light is best utilized in large, dark scenes where there is not enough available light, and a single flash may not be enough to light areas or objects deeper within the scene. Painting with light can be done using a flash unit, or a powerful flashlight. Objects further from the camera will require more

light than objects that are closer. Light will need to bounce off an object to be recorded, so avoid painting areas such as the sky.

Procedure: There are two commonly used techniques to paint with light. Both will require the Camera be placed on a sturdy tripod, focused on an object, switched to manual focus, and a locking shutter release cable be used.

Technique 1: Open the shutter, locking the button on the shutter release in place, and stand behind the camera, either “popping” the flash numerous times or shining a flashlight in various areas of the scene.

Release the shutter locking button, thus closing the shutter. Review the resulting image and adjust the time the shutter is open and/or how the light was applied to the scene for any additional photographs.

Technique 2: This requires two people. One person will stay by the camera and cover/uncover the lens with a dark cloth or piece of foam core while the shutter is locked open (it is important not to bump the camera/lens during exposure). A second person will walk in front of the camera but attempt to be just outside of the camera's view and/or hide behind objects within the scene (such as a tree, vehicle, etc). Once out of view, the second person will signal to the first person to uncover the lens, the second person will "paint" the scene with light, person two asks person one to cover the lens while person two moves to another location to "paint" again. Repeat the process as many times as necessary to fill the scene with light.



Fig. 3-4 In the image on the left, the photographer did not move their flashlight as much as they did on their second attempt in the image on the right. It should also be noted that areas closer to the camera require less light than the areas further from the camera. Only add light to items that reflect light back, pointing a light towards an empty sky will add nothing of value to the exposure.



Fig. 3-5 In the image on the left, the photographer is standing behind the camera when popping a flash into the scene. In the image on the right, they are popping the flash from the left, which helps to show details such as the tire tracks in the grass in the right of the image.



Fig. 3-6 This image was captured at night using Technique #2 with the lens being covered as a second person walks around popping a flash into the scene. You can see 4 areas where the flash is seen behind a tree in the distance. In this image, the shutter remained open for over 3 min, being covered between the flash being popped.

VII. Autopsy Photography

Camera Settings:

Exposure Mode: Manual “M”

File Format: JPEG Large/Fine

ISO: 100-400

Aperture: f/8-f/16 (adjust for depth of field)

Shutter Speed: As appropriate for meter reading.

Lens Stabilizer: “ON” as camera will likely be handheld.

Lens: Zoom 24-105mm, focal length between 30-50mm for most accurate human perspective.

Focus: Automatic or manual. Focus as appropriate for areas on body

Flash: On and Off camera flash as needed, E TTL or manual (power down from 1/1).

Summary: Like a Crime Scene, a systematic approach is recommended when taking the Photographs at an Autopsy. When possible, you will want to document the process from the very start, telling a pictorial story from the opening of the body bag until the exam is complete.

Autopsies can move at a quick pace and will require the photographer be ready to jump in get the photos needed, and quickly jump back out again. Much of the photography may be directed by the pathologist.

Procedure: Begin by photographing the body bag and the seal. Once the bag is opened. Photograph the body “as is” and any identifying features of the body, such as tattoos scars, piercing, etc. Some of these features can be rephotographed once the body has been cleaned and further examined. Identification photographs are important, so ensure that a frontal image of the face is captured. Use a ladder or step stool and normal lens when photographing the overalls, head shots, inside the body cavity, or as needed to avoid distortions. When photographing features on the body, an orientation photograph should be captured of that feature in reference to a physical structure or “landmark” on the body. It should be captured with as wide a view as practical without showing any

distracting elements in the background. A second, close-up photograph should be captured filling the frame with the feature in question. If a scale is to be used in relation to the feature, take one orientation photograph, one close-up photograph without the scale, and an additional close-up photograph with the scale.

VIII. Vehicle Photography

Camera Settings:

Exposure Mode: Manual “M”

File Format: JPEG Large/Fine

ISO: 400

Aperture: f/8-f/16 (adjust for depth of field)

Shutter Speed: As appropriate for meter reading. A tripod is essential for longer shutter speeds. Avoid $<1/60^{\text{th}}$ for handheld.

Lens Stabilizer: “OFF” if camera is on a tri-pod, “ON” if camera is being handheld.

Lens: Zoom 24-105mm, focal length between 30-50mm for most accurate human perspective.

Focus: Automatic or manual. Focus as appropriate for items in vehicle.

Flash: Off camera flash as needed, E TTL or manual (power down from 1/1).

Summary: Like a Crime Scene and an Autopsy, a systematic approach is also recommended when taking the initial record photographs of a vehicle. These photographs should include the exterior of the vehicle, all interior compartments, any obvious damage, and anything commonly used to identify a specific vehicle such as the VIN number, the license plate number and any other serial numbered window stickers.

Procedure: Begin at a logical point such as the front of the vehicle, being sure to include the license plate if present. Work your way around the car until the exterior is documented. Reflective

paint on vehicles can be problematic when using flash, you may want to consider using a tripod with available light. Approach the interior of the vehicle in a

systematic way as well. After items inside the vehicle are photographed in-situ, they can be removed from the vehicle for additional photographic documentation or to access other areas such as a glove box or console compartment. Using the flash off camera will allow for light to fill areas such as under seats and into map pockets on doors.

IX. Impression Photography

Camera Settings:

Exposure Mode: Manual “M” or Aperture Value

File Format: RAW+JPEG Fine
ISO: 100

Aperture: f/16

Shutter Speed: 1/125th

Lens Stabilizer: OFF (use tripod)

Lens: Macro, fixed 50mm or 100mm for Fingerprints. For larger areas such as footwear, 40-70mm (50mm is ideal)

Focus: Manual focus, if a 3D impression, focus on the bottom of the impression.

Flash: Off camera flash with extension cable or wireless trigger. Used at oblique angles to cast shadows or use as transmitted light. Flashlights may also work with longer exposures.

Summary: Impression evidence can range from fingerprints, to footwear, to tire tracks, to bite mark impressions. The photography of impression evidence that will be used for comparison requires proper scaling of the impression and often requires more advanced lighting techniques.

Procedure:

- 1:** Document the location of the impression on the item or within the scene with general overall photographs.
- 2:** Scale the impression as described earlier in Section 3.
- 3:** For fingerprints or partial impressions, use a macro lens. For larger impressions, use ~50mm

if possible, to avoid any distortion in the image.

- 4:** Ensure the camera back is parallel to the impression and scale, the impression and scale fill the viewfinder, and that lens is centered perpendicular, directly over

the impression. **5:** Use a shutter release or the camera's self-timer when capturing photographs to avoid camera shake. **6:** Try using available light, oblique lighting, and if the substrate is clear or translucent (such as glass) transmitted light that comes from behind the item. Trying various angles of light will produce different resulting images as will using different light sources such as flash units and flashlights. **7:** For 3D impressions with depth, such as a footwear impression in soil, light with the light source at a lower angles, casting shadows on the impression. Move the light around the item to cast different shadows for each image. **8:** For larger impression, such as a tire impressions, use a longer scale in addition to the forensic scale, the longer scale will remain in place as you move the smaller scale along to document the impression. Be sure to overlap any photographs captured of sections in larger impressions.



Fig. 3-7 These three photographs show the effect of the direction of light on the appearance of the details in a footwear impression. All three photographs are of the same footwear impression. The photograph on the left was taken with the flash on camera and is limited in pattern detail due to the lack of shadows. The center photograph was taken with the flash placed at a low angle on the right side of the impression. The right photograph was taken with the flash at a low angle at the bottom of the impression.



Fig. 3-8 It is recommended that a minimum of four images be captured of impressions, each lit from a different angle as illustrated above. Additional images lit from additional angles are beneficial.

Camera Settings:

Exposure Mode: Manual “M”

File Format: RAW+JPEG

Fine

ISO: 1600 (lower if fine detail needs to be recorded)

Aperture: f/8 (for more depth of field f/11)

Shutter Speed: Start with 15 to 30 seconds more time if needed.

Lens Stabilizer: OFF (use tripod)

Lens: Zoom 24-105mm, focal length between 30-50mm for most accurate human perspective.

Focus: Manual Focus

Flash: Underpowered, pop sometime during the exposure to show background.

X. Luminol Photography

Summary: The important thing to remember with Luminol (or BluStar) photography is to have camera equipment setup and have your exposures ready prior to applying the chemical. A test photo or two should be taken prior to application of chemical to ensure amount of flash (or flashlight) is not too bright in the scene. The goal is to create a log exposure, that will capture the luminol reaction, and sometime during that exposure, to add a small amount of white light for

additional background information to record in the image.

Procedure: 1: Set the camera on a sturdy tripod and focus on the area or item of interest in the scene. Switch the lenses focus to manual to prevent the lens trying to refocus once it's dark. **2:** With the available light off, open the shutter and add a small amount of light to the scene by popping a flash off a wall or ceiling, or turning room lights on, and then off again. Close the shutter and review the resulting image. It is better to have a darker exposure than lighter, as the goal is to capture just enough information to know what's in the image. Power down the flash or lessen the time the lights are on as needed **3:** Once an exposure is established, repeat the process as above, but leave the shutter open while the Luminol is being applied. Be careful that the camera is not move or bumped while the shutter is open. Review the image and add time as needed. Bright luminol reactions will record in less time than faint luminol reactions. When in doubt, expose for longer periods of time.

This is an *available light* exposure, using room light with the camera on a tripod.



Here the lights in the room were turned off, the camera's shutter was opened for 10 seconds. While open, a flash was bounced off the ceiling at ¼ power.



This is a 120 second exposure without the additional light added. The luminol is captured well, but it is difficult to tell what else is in the image.

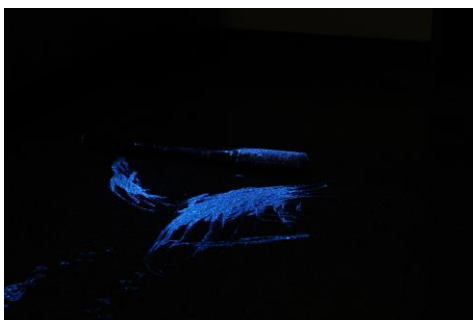

This is also a 120 second exposure. Sometime during the exposure, the flash was bounced off the ceiling at ¼ power.



XI. Alternate Light Source (ALS) Photography

Camera Settings:

Exposure Mode: Aperture Priority (Av)

File Format: JPEG Fine for general, RAW for comparison images

ISO: 400

Aperture: f/11 or f/16

Shutter Speed: Camera will select when in Aperture Priority mode

Lens Stabilizer: OFF (use tripod)

Lens: Zoom 24-105mm, focal length between 30-50mm for most accurate human perspective.

Focus: Manual Focus

Flash: None

Summary: Photographing an area in a scene or on an item using an ALS is similar to general documentation photography, however the light used will be a specific wavelength (vs white light) and will often require the use of a barrier filter to be placed in front of the lens.

Procedure: A wavelength and barrier filter combination should be determined prior to the photography being needed. This is most often determined by the search technique or examination

taking place prior to the need for photography. Place the selected barrier filter in front of the lens, being careful not to touch the filter to the lens unless it is a filter designed to be attached to the lens. Once the filter is in place, and the ALS unit's light is directed towards the area of interest, refocus the camera. Depending on the intensity of the ALS, the exposure may be several seconds in duration. On the following page is a chart for frequent light and filter combinations.

Evidence	Wavelength	Filter
Bitemarks/Bruises	<400nm	Visible Pass
Bitemarks/Bruises	415-445nm	Yellow
Bitemarks/Bruises	455-515nm	Orange
Bitemarks/Bruises	535-575nm	Red
Blood (Untreated)	415-455nm	None
Blood (Fluorescein)	455nm	Orange
Body Fluids	<400nm	Visible Pass
Body Fluids	445-515nm	Orange
Bones and Teeth	455-515nm	Orange
Gunshot Residue	455nm	Orange
Hair and Fibers	<400nm	Visible Pass
Hair and Fibers	415nm	Yellow
Hair and Fibers	455-515nm	Orange
Hair and Fibers	535-575nm	Red

Chapter 4

Multimedia Evidence (Image/Video/Audio)

Multimedia evidence covers a wide variety of image, video, and audio related data that can be created or collected as part of an investigation. This type of evidence is more prevalent than ever with the various capture devices recording everyday activities. From cell phone video to doorbell cameras to surveillance cameras, multimedia evidence for a single investigation can be captured in several different file formats across a variety capturing devices. Some of the more common areas where evidence is currently created or collected:

- *Video from home and business surveillance systems.*
- *Video made by or of persons involved in criminal activities.*
- *Video of body worn cameras and dash video cameras.*
- *Recordings of investigations.*

In addition, video can also be used as a tool to further assist in an investigation, some examples might include:

- *A realistic view of the overall scene based on a continuous recording of what a viewer sees, rather than an overall pictorial.*
- *Real time video feed (i.e.: drone surveillance) planning or documentation.*
- *A depiction of a particular event in motion that would not be suitably depicted through still photography.*
- *A record of a new or unusual technique developed in the field to process the scene or collect evidence.*

I. Crime Laboratory Imaging Services:

The Forensic Imaging Unit provides Forensic Video and Image Analysis and multimedia services for many types of digital evidence.

Examples of FIU Video and Image Analysis services include:

- Digital conversion of old media to digital files
- Demultiplexing camera views
- Isolation and clarification of objects/time periods in video
- Image clarification
- Timeline assembly of events
- Redaction
- Image/Video Comparison

Please contact the Crime Laboratory if the Forensic Imaging Unit can assist you with your evidence or questions.

II. Recording Video and Audio in the Field

When recording video or audio as part of an investigation an audio slate is suggested to be recorded at the beginning of each recording, stating the:

- a. Camera operator's name and agency
- b. Personnel present from agency
- c. Date, time, and exact location of recording
- d. Agency case number
- e. Any other information that may be relevant to the recording.

Each video or audio file produced should be traceable to the case, date produced and name of those involved.

III. Video Capturing Procedures

Crime Scenes

Include an audio slate at the beginning (see Section II). If narration or sound is not relevant, the camera's sound recording mode or microphone can be turned off. If a microphone cannot be disabled, care should be taken as to any sounds, or conversations that may be picked up during recording.

Using a very slow panning speed, pan the area to provide an overall view of the entire scene. Complete 360° pans should be made of exteriors of buildings and surrounding area, looking toward the structures and also away from the structures to the surrounding area.

When recording a walk-through of the scene try to avoid "jerky" camera movements, either right to left or up and down. Movement should be as smooth as possible. An alternative to the "walk-through" technique would be to record the scene as if photographing it using the four basic views from a stationary position.

Avoid excessive zooming in on items, only utilize the zoom when necessary and keep your zoom speed slow. Still photography is best for recording individual items and fine details.

When possible, do not include equipment, personnel, or unnecessary elements in your video. Be careful of reflective surfaces, such as mirrors, that may show your reflection or other items in the video.

If light levels are too low where camera will not record or camera gain must be used, consider using an on-camera video light or additional light source. Some cameras have a night mode that will record in infrared,

care should be taken in using this mode as it will not accurately record what the human eye is able to see.

Interviews and Interrogations

Interviews and interrogations require a different procedure than for crime scenes. See State Statutes for specific legal requirements. The following are general guidelines for consideration:

- The audio/video recording is **always** left on.
- The audio slate should include at a minimum the names of all persons present, the date, the starting time, the agency and the location.
- Whenever you stop or restart the recording, an audio slate should be including in the recording to explain why the recording is being turned off or resumed.

Surveillance

Retail/property surveillance and covert investigative surveillance are the two most common types of surveillance video captured in legal matters. When in a position to install camera systems or be an advisor to someone who is, the most crucial element is camera placement. Ideally video captured at eye level provides the most valuable information. Cameras placed up high, and covering a large area, work well for capturing an activity taking place in the video, but can be limited in detail when looking to identify people or items in the video. Second to camera placement limiting the compression of the camera files as much as feasible.

IV. Multimedia Evidence Collection

To maintain the integrity of the evidence, data should be collected in the native or proprietary format it was originally recorded in whenever possible.

For example: some DVR systems will allow for a video to be downloaded or exported in a non-proprietary, common file format, allowing for the video to be viewed in a variety of video players. This should be taken into consideration as these methods often further compress the video data.

Steps to consider when collecting evidence

- Notes should be taken detailing the methods used, and steps taken
- Establish if data is stored locally or in a cloud location
- Collect/copy the original files bit-for-bit whenever possible
- Generate and maintain a hash verification of original data

V. Analogue Media

While not as commonplace as it once was, some evidence is still recovered on older media such as magnetic tape (i.e.: VHS tape), film or memory cards. It is recommended that this type of media be treated as physical evidence. Attempting to play or view old media may irreversibly damage any information it contains. Please contact the Crime Lab with any questions on digital media conversion options.

VI. Digital Media

Digital media can be stored in a variety of ways and locations. When collecting Digital Media, it is important to know where the data is saved and recover bit-for-bit copies of that data. Some data may reside on a local PC's hard drive, some may be saved on a cloud server.

Some systems may record over or delete an event when space becomes limited. Therefore, data should be recovered as soon as possible.

Chapter 5

Crime Scene Sketch

The crime scene sketch is an invaluable aid in recording investigative data. It is a permanent record that provides supplemental information that is not easily accomplished with the exclusive use of crime scene photographs and notes. A crime scene sketch depicts the overall layout of a location and the relationship of evidentiary items to the surroundings. It can show the path a suspect or victim took, and the distances involved. It can be used when questioning suspects and witnesses. During trial, the crime scene diagram correlates the testimony of witnesses and serves as a tool for relaying reference and orientation points to the prosecutor, judge, and jury.

I. Sketching the Crime Scene

Before beginning a sketch, obtain a comprehensive view of the scene. Determine the sketch limits – decide what to include and what to exclude. If the scene is complicated, a number of sketches may be necessary for adequate documentation.

Types of Sketches

- Overview sketch: Consists of a bird's-eye-view or floor plan sketch of the scene. This is the most common type of sketch and consists of items on the horizontal plane (see Figure 5-1).
- Elevation sketch: Portrays a vertical plane rather than a horizontal plane. Examples include bloodstain patterns on vertical surfaces such as walls or cabinetry and bullet holes through windows (see Figure 5-2).
- Exploded view or cross-projection sketch: Consists of a combination of the first two sketches. It is like a floor plan except the walls

have been laid out flat and objects on them have been shown in their relative positions (see Figure 5-3).

- Perspective sketch: Depicts the scene or item of interest in three dimensions. It is the most difficult sketch to create and requires some artistic skill (see Figures 5-4 and 5-5).

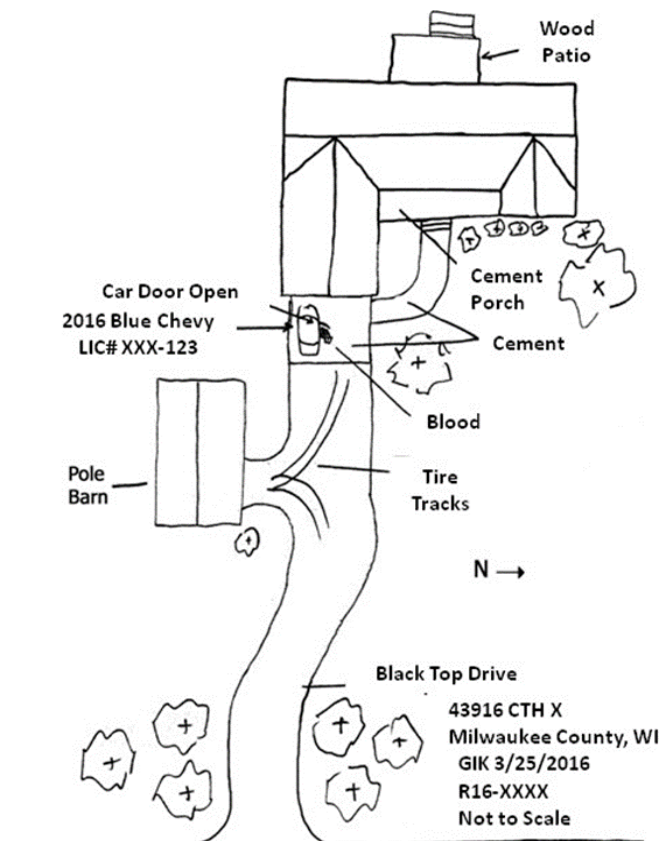

Fig. 5-1 Overview sketch of an exterior crime scene.

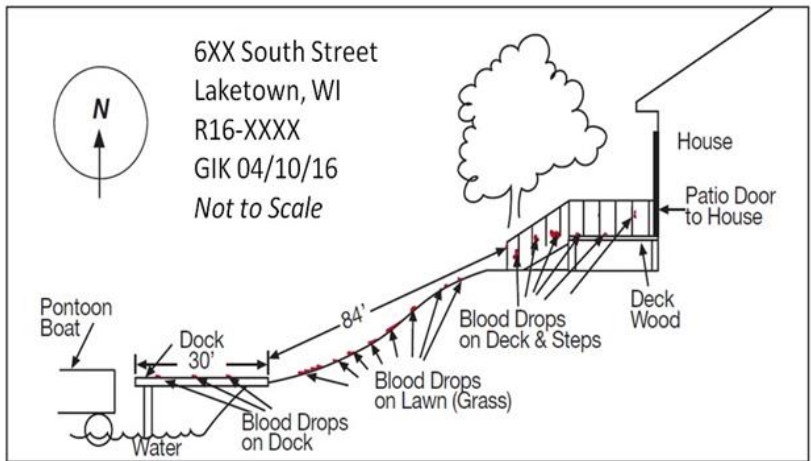

Fig. 5-2 Elevation sketch illustrating a blood trail.

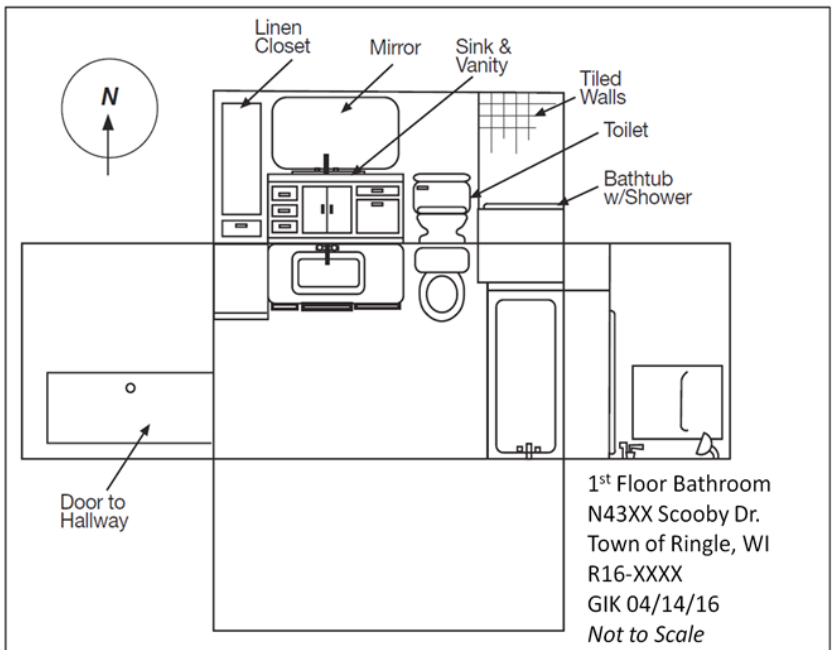

Fig. 5-3 Exploded view sketch of a bathroom.

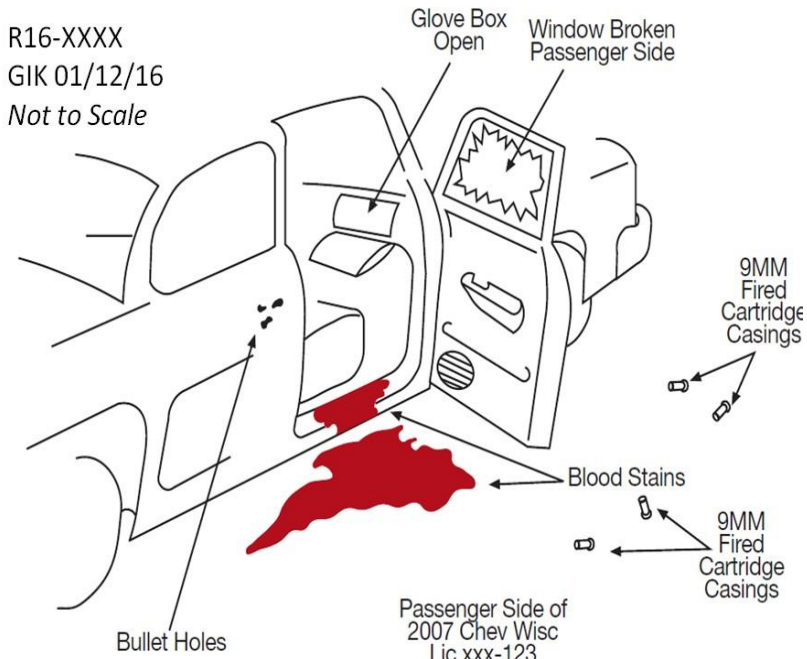

Fig. 5-4 Perspective sketch of the passenger side of the vehicle.

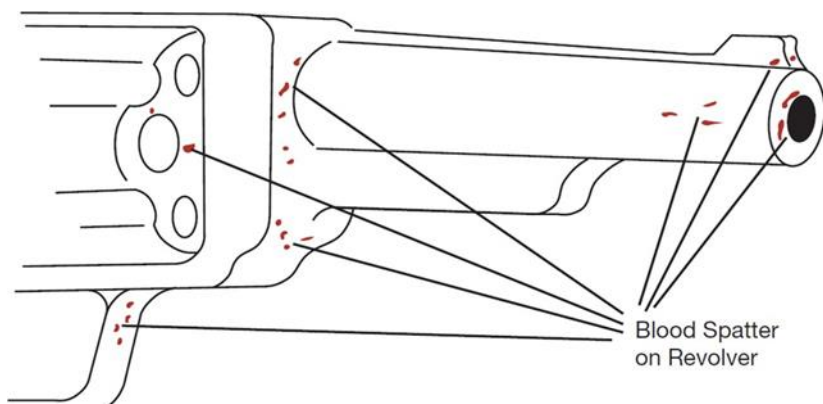

Fig. 5-5 Perspective sketch illustrating suspected blood spatter on a revolver.

To Scale or Not to Scale

- **“Drawn to Scale” diagrams**
 - To avoid a distorted view of the scene, measurements must be reduced in proportion so that they bear correct relationship to each other.
 - Select the scale of the diagram by fitting the longest dimension in the scene to the area of the paper being used.
 - Graph paper should be used when creating this type of sketch. Each block represents a specified length of measurement. Use convenient units for the scale (one block = 1 foot).
- **“Not to Scale” diagrams**
 - Sketch can be accomplished more quickly than a scaled diagram.
 - Items are placed in the diagram based on approximation. This type of diagram may provide a distorted view of the scene. Correct proportions and relationships between objects may not be maintained.
 - Measurements are recorded on the sketch or in a chart.
 - This rough sketch may be used to complete a scaled diagram later.
 - These diagrams should be clearly marked ‘Not to Scale’.

Equipment

- Supply of writing implements – pencils may be used for the overall sketch. A sketcher may choose to use red pencils to denote bloodstains, and highlighters or other colored pencils to mark different types of evidence on the sketch. Preserve a pencil created sketch in a permanent manner as soon as possible. A good method for

preservation is to photocopy the finished sketch and include the photocopy with the original.

- Blank paper – graph paper, while not essential, simplifies scale drawing.
- Drawing surface such as a clipboard.
- Measuring devices – tape measures are the most common tool used and should be at least 50 to 100 feet long. Other measuring devices may include a surveyor's wheel, a laser rangefinder, or a Total Station. GPS coordinates may be useful in locating an outdoor scene.
- Ruler for drawing straight lines, drawing to scale, and making very short measurements.
- Magnetic compass to determining true north.

Creating the Sketch

- If the scene is large, make a very rough sketch of the area while obtaining an over-all view of the scene. This initial rough sketch serves as a reference when making more complete sketches. Enlarged sections of this rough sketch can be made as separate drawings in order to bring out greater detail.
- Begin taking measurements and layout out a rough sketch
 - Lay down a baseline. This usually consists of the longest uninterrupted side of a room or, if outdoors, the curb line, building line, or even an imaginary line between two fixed points.
 - Take other measurements of the periphery of the scene and add them to the baseline.
 - Having established the outer boundaries of the sketch, add various objects in their proper positions.
- Measurements – write them down!
 - Measurements can be recorded directly on the sketch or in a chart.

- Long distances may be measured with the odometer on an automobile.
- Critical measurements should be checked by two people.

Locating Objects on a Sketch

All points require two measurements for a two-dimensional sketch. Three measurements are required for a perspective (3D) sketch.

- Rectangular coordinates – an object (item 1, see Figure 5-6) is located by making a measurement at right angles from each of two walls. Works well for indoor measurements.

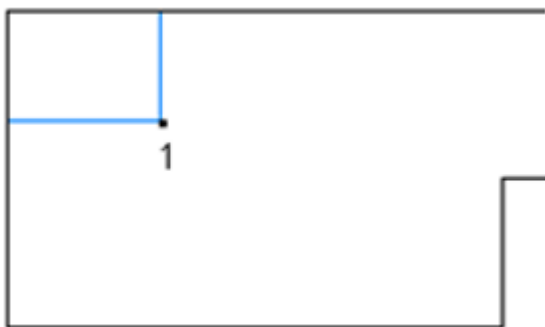

Fig. 5-6 Item 1 is located using rectangular coordinates.

- Transecting baseline – particularly useful in large, irregularly shaped outdoor areas
 - Transect the crime scene by laying down a tape measure along some convenient line so it crosses the entire area (blue line, see Figure 5-7).
 - Locate this line in the diagram from fixed points at the scene.
 - Locate objects in the crime scene by measuring their distance from this established baseline. Measurements must be taken at right angles to the tape.

- Record how far along the baseline the distance out to the object was measured. This provides the two measurements needed to locate the object.

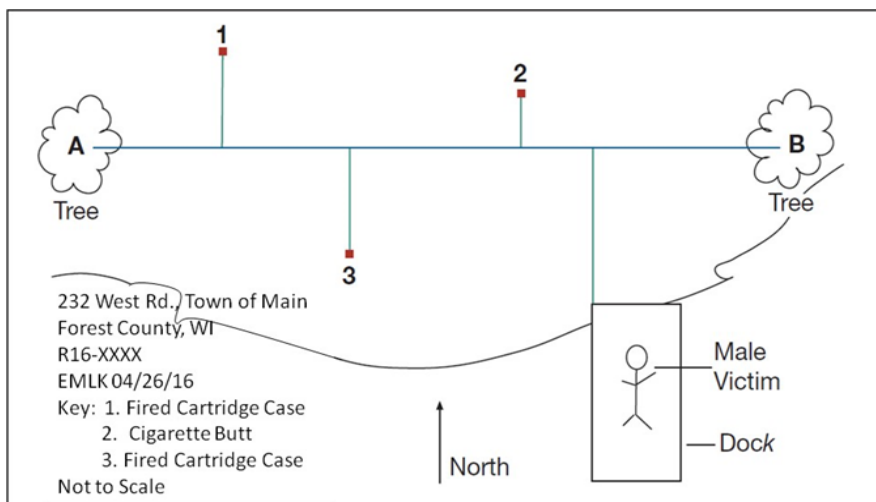

Fig. 5-7 Transecting Baseline. The blue transecting baseline AB is between two trees (trees can be marked with orange paint for later identification). The two measurements needed for each point are (1) how far each item is from the baseline (green lines north and south) and (2) how far east on the blue baseline from point A the objects are (distance to where the green lines intersect the blue). (*This is for illustration. Additional measurements would be collected for the body and the dock.*)

Triangulation – measurements are taken from two fixed points at the scene to the object you desire to locate. For example, item 1 in Figure 5-8 is located by taking measurements (length of the green lines) from two corners of the building.

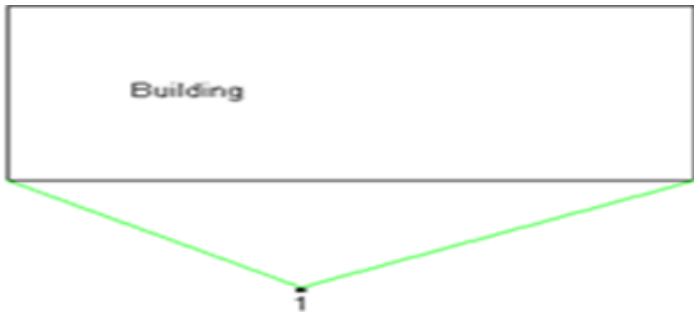

Fig. 5-8 Triangulation. Item 1 is located using triangulation from the two corners of the building.

Illustrating the Sketch

- Do not attempt to draw an object as it appears. Use symbols instead.
- Use lettered or numbered squares, circles, figures, or points to represent various objects in the sketch. Explain in the diagram key what these objects represent.
- If photography markers are used, ensure they correspond to same objects in the sketch. For example, if photo marker #5 is used to mark a handgun, make sure the handgun in the sketch is labeled #5.
- Label all doors and windows. Show with a curved line which way the door swings.
- Use an arrow to show the direction of the stairway.
- Use jagged lines to cut off unnecessary height or length.

Labeling the Sketch

The following should be recorded on the sketch:

- Address or location of scene
- Case number
- Date sketch was made and by whom
- A key to identify the different objects in the sketch
- An arrow to show the direction of north

- Scale used for the sketch or the statement "Not to Scale"

II. Computer Based Programs

Several CAD based programs are commercially available and can be used to create professional and accurate crime scene diagrams.

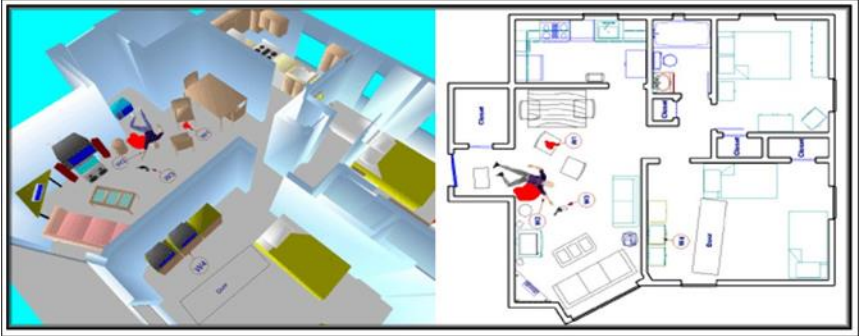

Fig. 5-9 Diagrams created using The Crime Zone™ software* and used with permission of The CAD Zone, Inc.

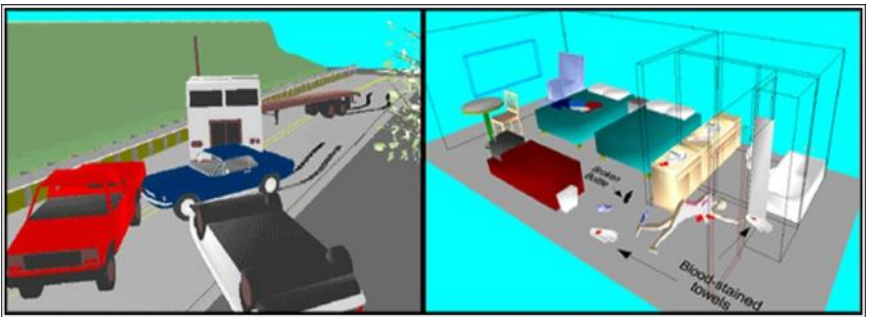

Fig. 5-10 Diagrams created using The Crime Zone™ software* and used with permission of The CAD Zone, Inc.

These types of programs can be used at the scene to record measurements and generate sketches or used at the office using rough sketch(es) created at the scene to generate sketches.

III. Latest Technology

Portable devices now exist that can perform a 360° scan of a crime scene in as little as 20 minutes, capturing millions of measurements of all objects visible to the scanner. Dozens of high-resolution images are captured automatically. The device requires only the space needed by a standard photographer's tripod. The data generated can be used to find the distance between any two points in the scene, to view the scene from any vantage point (including directly overhead), and to create a full- color, 3D model for investigative and courtroom purposes.

The National Institute of Justice's Forensic Technology Center of Excellence (FTCoE) at RTI International directed an effort with criminal justice system communities, law enforcement, industry, and forensic input to conduct a landscape study of 3D laser scanning instruments. The study was summarized, is soon to be posted by FTCoE and was located at commercial websites in abridged and complete forms at the time of this publication (see Leica's abridged version and Riegl USA's complete version*).

NOTE: The Laboratory does not endorse any one software program or device over another, nor does it endorse any one vendor over another.

Chapter 6

Bloodstain Pattern Analysis

Because certain scientific principles can be applied to blood, what may appear to be a random spatter of bloodstains at a crime scene allows a trained bloodstain pattern analyst to examine and draw useful conclusions as to how the blood may have been distributed.

Information gathered from the bloodstain patterns and other marks associated with it has proven a worthwhile forensic application.

I. Documenting Bloodstain Patterns for Analysis

The examination of bloodstain patterns has always been a part of crime scene investigation. Careful observation, measurement and documentation of the size, shape and pattern of bloodstains can reveal significant information in some cases, e.g., direction and angles of blood spatter, areas of origin and the minimum number of blows in a beating or stabbing event.

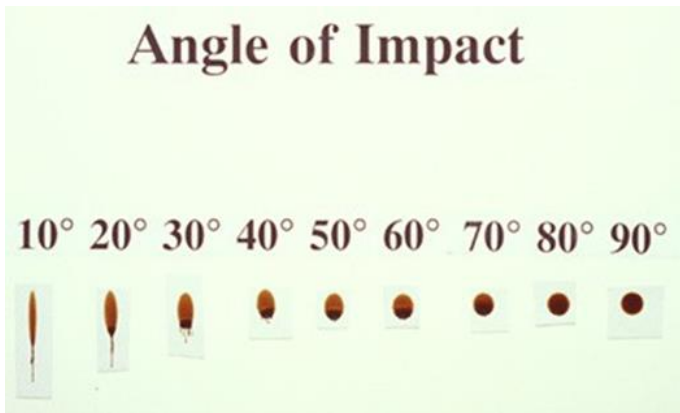

Fig. 6-1 The chart above demonstrates how the appearance of a blood drop will change depending on

the angle in which it impacts a surface. A blood drop that falls straight down at a 90° angle to a surface will be round in appearance. As the angle of impact becomes more acute, the blood drop elongates.

When bloodstains are found at a crime scene, the following information should be documented:

- Physical state (fluid, moist, dry)
- Amount present (few drops, small pool)
- Shape (smear, round drops)
- Exact location in relation to fixed objects
- Pattern of stains (all in one spot, trail)
- Atmospheric conditions (temperature, humidity)
- Date and time of observations
- Scaled and unscaled photographs of stains (see *Chapter 3 – Forensic Photography*). Videography is also an option.

It is essential to preserve bloodstain patterns until a trained bloodstain pattern analyst can examine the patterns. Although photography and videography are useful in recording some of the aspects of bloodstains at a crime scene, it does not substitute for the detailed examination.

Further information and guidance on bloodstain pattern analysis, training, and quality assurance in bloodstain analysis can be found at the resources location of The Scientific Working Group on Bloodstain Pattern Analysis (SWGSTAIN) <http://www.swgstain.org/resources>. The site also contains a document of recommended and defined terminology useful when working with or discussing bloodstain patterns.

Chapter 7

DNA Evidence and Standards

One of the most important developments in the field of forensic science in the past few decades has been the implementation of DNA testing. With this testing, crime labs can match stains to individuals and test extremely small amounts of biological material to assist forensic investigations. Wisconsin DNA laboratories work to adhere to the quality standards put forth by the FBI in their Quality Assurance Standards for Forensic DNA Testing Laboratories that influence guidance provided below.

I. Introduction

DNA, which stands for deoxyribonucleic acid, is the genetic material (or “blueprint”) that determines the characteristics of all living organisms. It is what provides uniqueness among human beings. While the vast majority of DNA is the same in humans, enough variations exist to allow discrimination between individuals with the exception of identical siblings. DNA is found in all nucleated cells (except red blood cells) and is the same throughout an individual’s body. The DNA of a person does not change over the course of their life, so that person’s DNA profile remains the same. (The only exception would be a bone marrow transplant recipient.) Half of each person’s DNA is inherited from their mother and half from their father. This is why DNA can be used in paternity testing. DNA is also a very robust molecule and can yield results years after a stain is deposited.

There are many applications of DNA testing beyond the field of forensics. It has been used in paternity testing, plant research, identification of missing persons and unknown remains, tissue matching for transplants, and identification of remains after mass disasters. DNA

testing was used extensively after 9/11 to identify victims.

There are three types of forensically interesting DNA: nuclear, Y chromosome, and mitochondrial.

Nuclear DNA

Nuclear DNA is found in the nucleus of cells and is the type of DNA testing generally utilized in crime laboratories. The areas of DNA that are forensically relevant provide no significant information about that individual other than sex. The most common type of nuclear DNA testing in forensics is **autosomal** testing, which consists of nuclear DNA located on the non-sex determining chromosomes. Autosomal DNA is unique to an individual except for identical siblings.

Y Chromosome DNA

Y chromosome DNA is a type of nuclear DNA found only on the male sex (Y) chromosome and is therefore present only in males. This type of DNA is passed on from father to son through the paternal bloodline, so a man, his brothers, his father and his male sons will all have identical Y DNA (barring a mutation). Y DNA testing is very useful for samples where a high level of female DNA is mixed with a much lower amount of male DNA. If autosomal testing was used on such a sample, the female DNA may mask any other profile present; however, with Y chromosome testing, the female DNA is in effect ignored, revealing only the male DNA. While not as discriminating as autosomal DNA, Y chromosome DNA may provide valuable information in a case.

Mitochondrial DNA

Mitochondrial DNA is not found in the nucleus of cells but rather in the mitochondria, the part of the cell

where energy is produced. Like Y DNA, mitochondrial DNA is not unique to an individual and is passed through the maternal bloodline. Barring a mutation, all maternally-related family members will have identical mitochondrial DNA. As a result, forensic comparisons can be made using a reference sample from any maternal relative. This type of DNA testing is used primarily on hairs and bones, very old remains, and remains that are severely degraded such as after a mass disaster.

Mitochondrial DNA testing is not available at the Wisconsin State Crime Laboratory but is available at no charge from the FBI. A number of private laboratories also conduct mitochondrial DNA testing for a fee.

STR Analysis (STRs)

The type of nuclear DNA testing currently in use in the WSCL is called Short Tandem Repeat analysis (STRs). STR analysis looks at short pieces of DNA which are repeated a specific number of times at a particular location on the DNA molecule. Think of it as analogous to railroad cars: each person has two tracks, one from each parent. On one track an individual might have five repeats (or boxcars); on the other, six repeats. At that particular location, that person has a type of 5, 6. Other people in the population may be the same type at that location, but as more and more locations are typed, differences between individuals will be obvious. The Laboratory currently analyzes 23 different areas of DNA for autosomal DNA testing.

There are many advantages of STR DNA testing. Due to the sensitivity of this method, results can be obtained from extremely small and/or degraded samples. This method is extremely sensitive and uses a very small amount of material. It is also highly discriminating among individuals.

There are disadvantages to this type of testing as well. Because of its sensitivity, care must be taken to prevent the introduction of extraneous DNA at a crime scene or during sample collection. Mixtures of DNA from different people are also common, especially on touched items, which can make interpretation of the results difficult or impossible. In instances when an adequate amount of material cannot be obtained, it may not be possible to generate a DNA profile.

Limitations and Concerns

Despite the revolutionary ways that DNA testing has changed forensic analysis, there are still some limitations to be aware of:

- DNA can be removed by washing
- Analysts need to be able to locate a stain on an item or know where DNA might be deposited on an item
- DNA analysis cannot determine when a stain was deposited on an item,
- Environmental factors such as mold, heat, humidity, bacteria and sunlight can destroy DNA very quickly
- The age of dried blood, seminal stains, or possible saliva stains cannot be determined
- In regard to touch evidence, DNA results cannot answer when or under what circumstances an individual's DNA was deposited on an item. Low levels of DNA from a person who did not have contact with the item can be transferred to an item
- Talking, coughing or sneezing near an item may introduce DNA to an item without contact by a person
- Whole blood transfusions or bone marrow transplants may alter blood composition. In these cases, collect an alternate standard for

DNA testing such as a buccal (cheek) swab in addition to the blood

- Very old or highly degraded DNA samples may yield results, may give an incomplete DNA profile, or may not yield results
- Hairs must have a root suitable for nuclear DNA analysis. The laboratory will microscopically examine the hairs, as necessary, to determine if a suitable root is present
- Processing an item of evidence prior to submission should be avoided. Processing chemicals may interfere with DNA testing and could lead to contamination

Contamination Prevention During Collection

The prevention of contamination is of vital importance in DNA testing at all stages of an investigation. The most important steps to always take are as follows:

1. Wear proper protective clothing:
 - a) Gloves
 - b) Mask/face shield
 - c) Glasses
2. Do not handle any items without gloves. Change gloves after handling each item.
3. Double glove method is preferred. May change only top gloves after each item collected.
4. Avoid handling any item where the DNA may be deposited – you may wipe it off (even with gloves).
5. Do NOT talk, cough or sneeze on or near DNA evidence.
6. Air dry items completely but keep away from fans or extreme heat (e.g., do not keep evidence in trunk of car).
7. Always collect and package stains (blood or otherwise) from different locations/areas separately.

8. Put each item of evidence in new paper bags or envelopes – one item per container. This includes swab boxes (except for multiple swabs from the same item or area of an item if multiple areas were swabbed, which may be packaged together).
9. Do NOT put your gloves in with the item of evidence. Dispose of them properly.

Packaging

- Package items separately in new, never used, paper bags, envelopes or cardboard boxes. Never package biological evidence or samples in plastic.
- Mark outermost package with biohazard warning label if applicable.
- Refrigerate liquid specimen(s), and mail at the beginning of week (ensure receipt of delivery) if hand delivery is not viable.

Collection and Submission of Standards

The laboratory should have standards from the victim(s), suspect(s), and/or elimination(s). Submit standards with other evidence for comparison purposes. **Submit buccal swabs or blood samples in all cases, even if it is known that the individual has a profile on file in CODIS.** Dried blood samples may be submitted as known reference standards for deceased individuals. If there are any circumstances where a standard cannot be obtained, please contact the laboratory.

<p>Buccal Swabs</p>	<ol style="list-style-type: none"> 1. Rub 2 sterile cotton swabs on the inside cheek and gum. <ol style="list-style-type: none"> a. First have the person rinse their mouth with water. b. Place the swab(s) in solid contact with the inner cheek and gum surface. Gently move the cotton tips in and out five or six times rotating the swab(s) while rubbing. A slight indentation should appear on the exterior of the cheek if the correct pressure is being applied. This may be repeated on the other cheek with the second swab. 2. Air dry the swabs and then package in a sealed swab box, envelope, or paper bag. 3. Label all layers of packaging with the first and last name and date of birth of the person from whom it was obtained. 4. Forward the sealed envelope to the laboratory. 5. Buccal swabs do not require refrigeration. <p>*Do not collect buccal swabs as standards if the mixing of body fluids through such contact as intimate kissing has recently occurred.</p>
<p>Liquid Blood Standards</p>	<ol style="list-style-type: none"> 1. A qualified clinical technician should collect approximately 5 milliliters of liquid blood and place the sample in a collection tube with a lavender or purple stopper. (For a blood alcohol or drug test, refer to the toxicology section for proper sample collection.) 2. Label the vial and all layers of packaging with first and last name

	<p>and date of birth of the person from whom it was drawn.</p> <ol style="list-style-type: none"> 3. Package the vial in a crush-proof container that will contain all contents and prevent leakage during handling, storage, and transport. Include absorbent material sufficient to control any leakage or spill. 4. Refrigerate, do not freeze, liquid blood samples.
Dried Blood Standards	<ol style="list-style-type: none"> 1. Blood stain cards or spot cards prepared by a qualified entity (e.g., medical examiner's office) should be labeled with the first and last name and date of birth of the person from whom it was collected. 2. Label all layers of packaging with the first and last name of the individual, the initials of the preparer, and the date. 3. Dried blood standards do not require refrigeration.

Collection and Submission of Evidence

Bloodstain Evidence	<p>Avoid processing items for latent prints before submitting to lab for biological testing. The processing may interfere with biological examinations and/or introduce contamination.</p>
	<p>Liquid Blood (e.g., pool of blood on floor)</p> <ol style="list-style-type: none"> 1. Collect a sample with a sterile cotton swab(s) (DNA-free swabs are preferred). Two well-coated swabs are sufficient for analysis purposes. 2. Dry at room temperature. 3. Package in swab box, envelope, or paper bag. 4. Label with appropriate information (refer to General Labeling

	<p>Guidelines).</p> <p>5. Seal and initial.</p> <p>Dried Blood</p> <ul style="list-style-type: none"> • Submit the item, if feasible. • When not feasible to submit the entire item: Preferred method for fabric items: <ol style="list-style-type: none"> 1. Photograph the object/stain. 2. Cut stain from item (i.e., sofa cushion or carpet). <p>Or</p> <p>Preferred method for hard surfaces:</p> <ol style="list-style-type: none"> 1. Swab suspected blood with a sterile cotton swab (DNA-free swabs are preferred) that is slightly moistened with distilled water. Swab the suspected stain gently, but with enough pressure to collect the cellular material. Follow up with a dry swab, especially on items with hard surfaces (such as weapons, wood, etc.) to collect any cells remaining. 2. Air dry swabs completely. 3. Package in swab box, envelope, or paper bag. (Wet/dry swabs from the same stain/area should be packaged together.) 4. Label package appropriately, then seal and initial.
Sexual Assault Evidence	The victim of a sexual assault should be examined by appropriate personnel (e.g., Sexual Assault Nurse Examiner) as soon as possible following the assault and before the affected areas (pubic area, vagina, rectum, etc.) or clothing are washed or cleaned.

A Medical-Forensic Evidence Collection Kit is available free of charge to medical facilities. This kit contains detailed instructions that should be used to collect appropriate samples from both male and female sexual assault victims and suspects. This evidence can be collected up to 120 hours after the assault.

Other standards and evidence to collect:

- Standards from consensual partner(s), if applicable.
- Standards from suspect(s), if known.
- Suspected semen stains on large items not feasible to submit to the lab (mattress, stains located on flooring, etc.) (follow collection protocols for blood stains).
- Clothing worn by victim at time of assault suspected to contain biological fluids or handled/removed by suspect(s).
- Condom:
 - The amount of possible seminal fluid in the condom should be considered during collection, packaging and storage. Great care should be taken to minimize leakage of semen from inside the condom.
 - If little/no liquid appears to be in the condom itself, it can be placed in a specimen jar and frozen until submitted to the laboratory.
 - If a large amount of liquid is present, one of the following procedures should be used:
 - a. Attach the opening of

the condom to the top or side of a specimen jar so the fluid cannot leak out. Label the jar/package so it is maintained in an upright condition. Freeze until submitted to the laboratory. Do not mail, submit in person.

- b. Using sterile cotton swab(s) (DNA-free swabs are preferred), collect all or as much of the fluid from inside the condom as possible. Allow these swabs to dry together, but separately from the condom itself. Package in a swab box, envelope or paper bag. Submit the condom in a separate package. Stand up another set of dry swabs and drape the condom over them, tent style, with the opening of the condom at the bottom. Allow to thoroughly air dry in a protected area. Package in a paper bag or envelope.

All swabs and items of evidence need to be **completely dry** before packaging occurs.

	Swabs collected from the same body area or from the same stain can be packaged together.
Possible Saliva	<p>Submit the item, if feasible. Describe to the laboratory possible areas on an exhibit (e.g., right sleeve of shirt) where possible saliva stains may be present.</p> <p>When not feasible to submit the entire item:</p> <ol style="list-style-type: none"> 1. Photograph the object/stain. 2. Cut stain from item (i.e., sofa cushion). Preferred method for fabric. <p>OR</p> <ol style="list-style-type: none"> 1. Swab suspected saliva with a sterile cotton swab (DNA-free swabs are preferred) that is slightly moistened with distilled water. Swab the suspected stain gently, but with enough pressure to collect the cellular material. Follow up with a dry swab, especially on items with hard surfaces, to collect any cells remaining. Preferred method for hard surfaces. 2. Air dry swabs completely. 3. Package in swab box, envelope, or paper bag. (Wet/dry swabs from the same stain/area should be packaged together). 4. Label packaging appropriately, then seal and initial. <p>Cigarette butts from the same container (e.g., ashtray) may be packaged together. Do not package the ashes.</p>
Hair Evidence	Remove visible hairs from the body or item with forceps and place in a paper fold. Place fold in outer envelope, label, and seal.

<p>Tissue (including fetal tissue) and Bone for DNA Testing</p>	<p>Submit bone and tissue samples for DNA analysis frozen in airtight plastic containers.</p> <p>All samples must be free of formaldehyde or formalin as these chemicals can negate DNA analysis.</p>
<p>Touch Evidence</p>	<p>Submit the item, if feasible. Describe to the laboratory possible areas on an exhibit (e.g., right sleeve of shirt) where the item was touched by the subject(s).</p> <p>When not feasible to submit the entire item:</p> <ol style="list-style-type: none"> 1. Swab the suspected area(s) on an item of evidence with a sterile cotton swab (DNA-free swabs are preferred) that is slightly moistened with distilled water. Swab the suspect areas gently but with enough pressure to collect the cellular material. Follow up with a dry swab, especially on items with hard surfaces (such as weapons, wood, etc.) to collect any cells remaining. For touched items, use only one or two swab sets for sample collection. (A wet swab followed by a dry swab is one set.) 2. Air dry swabs completely. 3. Package in a swab box, envelope, or paper bag. (Wet/dry swabs from the same stain/area should be packaged together). 4. Label appropriately, seal and initial.
<p>Evidence Potentially Infested with Insects</p>	<p>Insect activity needs to be neutralized prior to laboratory submission. Freezing items that are potentially infested is usually successful; however, it may take up to 2 weeks to be effective.</p>

<p>Fingernail Evidence</p>	<p>When there is reason to believe evidence may exist under the patient’s fingernails such as blood, skin, hair, fibers, etc., the fingernails should be gently scraped with a wood or plastic applicator stick or toothpick into a clean, paper envelope. Alternatively, the fingernails can be clipped and the clippings placed into the envelope. Each hand should be done separately (not each finger). Properly label and seal each envelope.</p> <p>Fingernail swabbings can be used if the fingernails are short.</p> <ul style="list-style-type: none"> • Moisten the swab with sterile water and swab the front edge and underside of the fingernails. • Use one swab for each hand. • Allow the swab to thoroughly air dry. • Package the swabs in a clean, properly labeled paper envelope and seal. <p>Finger Swab(s) (Suspects Only):</p> <ul style="list-style-type: none"> • If the victim was digitally assaulted, the suspect’s finger(s) should be swabbed with a swab (one per hand) moistened with sterile water. • Follow the wet swab with a dry swab (“two swab method”). • Allow swabs to thoroughly air dry. <p>Package the dried swabs in a clean, properly labeled paper envelope and seal.</p>
<p>Bite Marks</p>	<p>Bite mark evidence must be photographed to document the impression. <i>See Chapter 3 - Forensic Photography</i> for the proper method to photograph evidence.</p> <ul style="list-style-type: none"> • Following photographic documentation, the bite mark should be swabbed with a swab moistened with sterile water.

	<ul style="list-style-type: none"> • Follow the wet swab with a dry swab (“two swab method”). • Allow swabs to thoroughly air dry. • Package the dried swabs in a clean, properly labeled paper envelope and seal.
Clothing	<p>Articles of clothing worn by the victim and suspect (if possible) should be collected for submission to the Laboratory to be examined for seminal stains, blood stains, foreign hairs and fibers or other trace evidence adhering to the clothing. In addition, items at the crime scene may provide important evidence that associates the victim and/or the suspect with the scene.</p> <p>Procedure for collection of clothing:</p> <ol style="list-style-type: none"> 1. Clothing of the victim must be kept separate from those of the suspect at all times. 2. Clothing worn at the time of or immediately after the offense should be recovered and preserved. This includes undergarments, towels, tissues, and sanitary napkins and/ or tampons (only if used during or immediately after the offense). 3. Garments should be handled as little as possible to avoid the loss of trace evidence. <p>Package each item of clothing separately in a clean, properly labeled paper bag and seal.</p>

Chapter 8

DNA Databank

Wisconsin collects known reference DNA samples from all felony and misdemeanor convictions as well as a subset of violent felony arrests. The DNA Databank Unit at the Wisconsin State Crime Laboratory receives, verifies acceptability, and processes the reference DNA samples for entry into the Combined DNA Index System or CODIS. The DNA Databank Unit is responsible for understanding and applying the Wisconsin statutes, rules, regulations, administrative codes, and standards required to ensure the quality and security of the data stored in the database.

The DNA Databank receives thousands of reference DNA samples in the mail monthly that were collected by trained law enforcement using a DNA Databank collection kit that is provided at no charge to the agency. The collection device used in Wisconsin is the EasiCollect+ device which allows the transfer of DNA from the cheek cells of an individual to chemically treated papers designed for collection & preservation. Upon receipt in the mail, the DNA Databank staff review the submission form and the collection device for completeness and adhere barcodes for internal tracking.

On April 1, 2015, Wisconsin implemented Wisconsin Act 20 that enforces collection of DNA from a subset of violent felonious acts at arrest (adults and juveniles), all misdemeanor convictions from adults, a subset of misdemeanor convictions from juveniles, and all felony convictions (adults and juveniles). Wisconsin statute §165.76(1)(as) has been interpreted to be operational. That is, it was deemed that the legislative intent was to limit misdemeanor conviction collections for individuals in which the date of the offense had to have occurred on or after April 1st, 2015. In addition, Wisconsin Act

20 prevents WSCL from processing an arrest DNA sample unless probable cause is established by the courts and requires destruction of an arrest DNA sample at one year if probable cause is not established. After verification of the fingerprints on the submission form and the confirmation of the qualifying event, the reference DNA sample is processed in the DNA Databank. The DNA Databank uses an automated instrument that punches a tiny hole from the FTA card the size of a pencil tip into a 96 well plate. The instrument repeats this step for 90 samples at a time and adds liquid reagents so that the DNA for each reference DNA sample can be amplified and then separated by a genetic analyzer. The tiny punch contains all of the information necessary to develop a complete DNA profile for entry into CODIS.

I. The Combined DNA Index System (CODIS)

CODIS is a software program developed and provided by the Federal Bureau of Investigation and each participant must follow state and federal guidelines to participate in the use of the software. The State CODIS Administrator is responsible for ensuring adherence to the state and federal regulations. The purpose of CODIS is to allow federal, state, and local laboratories to compare profiles thereby linking crime scenes to each other or to a reference DNA sample collected from a known arrestee or convicted offender. This linkage provides the law enforcement community an investigative lead to pursue. Importantly, through the expansion of database laws, the number of DNA profiles being searched in CODIS continues to expand and each year new and old cases continued to be aided and solved.

Networked through the Combined DNA Index System (CODIS), the Wisconsin DNA Databank has the ability to search DNA profiles at the State and Federal levels. The Local DNA Index System (LDIS) connects to the

State DNA Index System (SDIS) which links to the National DNA Index System (NDIS). The primary purpose of CODIS is to assist law enforcement agencies with leads for investigations in which biological evidence was recovered.

The FBI provides oversight of CODIS-participating laboratories and sets forth quality assurance standards and requirements for upload and search by NDIS participating laboratories with their Quality Assurance Standards for DNA Databasing Laboratories. Similarly, the Wisconsin State Crime Laboratory sets forth procedures for upload and search within Wisconsin by SDIS participating laboratories while also in compliance with state statutes and NDIS standards. CODIS specific rules exist for profile upload and searching, and not all profiles obtained from items of evidence can be uploaded into the database.

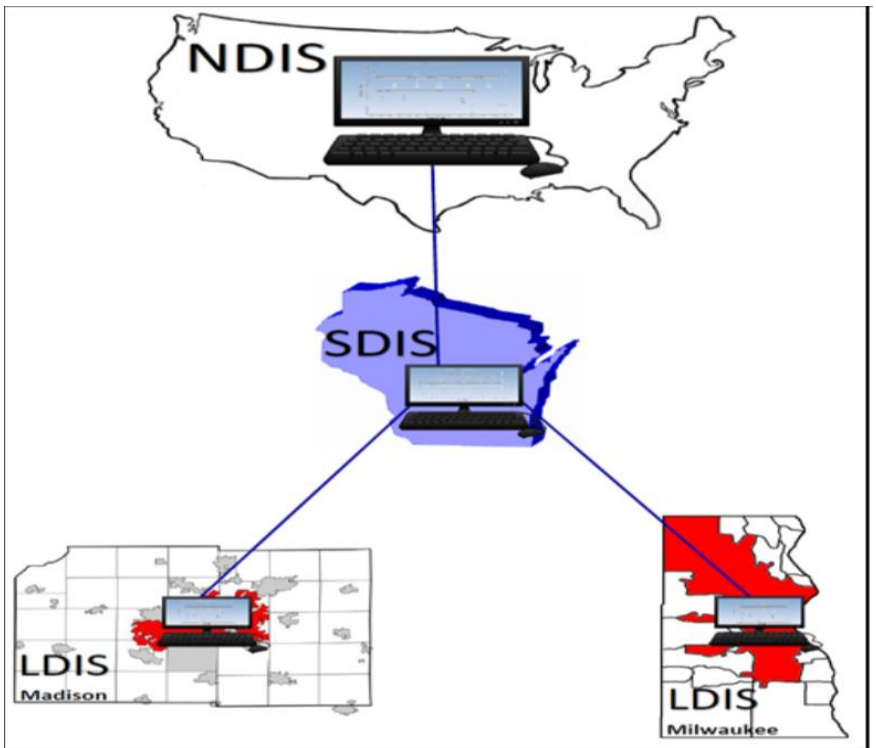

The Local DNA Index System (LDIS) includes DNA profiles developed by the local laboratory. LDIS is maintained locally and administered locally for compliance and connectivity to larger database indices outside of the laboratory while also maintaining the laboratory's Quality Assurance Index. There is an LDIS laboratory in Madison and one in Milwaukee.

II. State DNA Index System (SDIS)

The DNA Databank Unit of the Wisconsin State Crime Laboratory receives, verifies acceptability, evaluates and maintains a repository of high-quality reference DNA samples of individuals required by Wisconsin State Law to provide a sample for entry into CODIS. The DNA Databank Unit also maintains a repository of forensic evidence profiles for comparisons against reference DNA samples. This collective repository for Wisconsin is referred to as the State DNA Index System (SDIS). It is important to emphasize that a database "match" is used for investigative leads. SDIS serves as support to LDIS as deemed necessary and when requested by the local laboratory.

III. The Familial Search Program

A substantial number of investigative leads provided by The Wisconsin DNA Databank are linked to high priority crimes such as sexual assaults or homicides and help bring resolution to many victims. As an additional investigative tool, and to serve the state of Wisconsin, the DNA Databank also has an active Familial Search Program. This program utilizes a software that deliberately searches the Wisconsin DNA Databank for first order biological relatives of unknown evidence profiles obtained from crime scene evidence. The Wisconsin Familial Search Program allows for new and significant investigative leads to previously unsolved violent crimes.

IV. DNA Databank Reference Sample Collection

Wisconsin DNA Database Collection Kits including a postage-paid return envelope are available at no charge to criminal justice agencies. These kits are for the collection of DNA samples for inclusion in the DNA Databank. These kits can be used for the collection of convicted offender samples as well as violent felony arrestees. These kits are not for the collection of known standards for submission to the DNA Analysis Unit or for the collection of evidence samples.

When preparing to collect a reference DNA sample, please ensure a Qualifying Event is identified. If a qualifying event is identified, confirm that a DNA collection is needed from the individual. For more information on qualifying events, please refer to the supplemental form on the Division of Forensic Sciences (DFS) website at <https://www.doj.state.wi.us/dfs/dna/dna-databank>.

Step 1. Verify the persons identify, and check for criminal history

If person does not have a State Identification Number (SID), collect a 10-print card and submit it to the Criminal Information Bureau (CIB).

SYLEVESTER T CAT	
Male / Unknown	
Born in Wisconsin; Citizen of USA;	
01/01/1941, 04/05/1946, 01/01/1956, 06/24/1969, 04/04/1946, 04/04/1947	
4'11"; 075lbs; Brown Eyes; Brown Hair;	
Dane County Humane Society, Madison, WI as of 01/01/1960	
FBI: 9444400	 MUST HAVE
STATE ID: WI415506	
DRIVERS LICENSE #:	WI-MEOWMEOWMEOW, WI-123456123456123, WI-MEWMMEWMEWMEW
EMPLOYER:	Unknown

Step 2. Check to see if the person has a DNA flag present. If the person has a flag, do not collect an additional DNA sample. If the person does not have a flag, then a DNA sample must be collected.

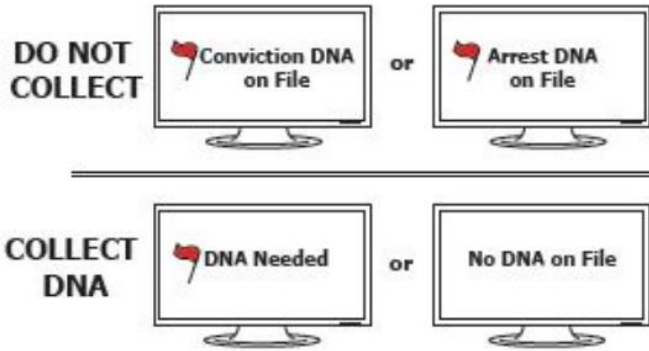

Step 3. Complete the Submission form. This form is located on the DFS website at <https://www.doj.state.wi.us/dfs/dna/dna-databank> or on Wilenet at <https://wilenet.widoj.gov>. The forms may be filled in electronically from either of these locations. Fingerprints are required to be added to the bottom of the form.

The image shows a 'PREVIOUS DNA EXTENSION: MEDICAL, WOUND COLLECTION SET SUBMISSION FORM'. The form includes the following sections and fields:

- PLEASE PRINT ALL INFORMATION:** Name (Last, First, Middle Initial), Date of Birth, Sex, Race, Height, Weight, Hair, Eyes, Complexion, and Other.
- SUBJECT INFORMATION:** If the submission is NOT COMPLETED CORRECTLY IT MAY BE REJECTED. Includes fields for Name, Address, and City/State/Zip.
- ARREST INFORMATION:** Arrested (Yes/No), Arrested on (Date), Arrested at (Location), and Arrested by (Name).
- COLLECTION AGENCY INFORMATION:** Agency Name, Address, City/State/Zip, and Agency Contact (Name and Phone).
- FINGERPRINTS:** A section at the bottom with a red arrow pointing to a fingerprint image. The text 'MUST HAVE' is written above the arrow.

Step 4. Prepare to collect the sample by putting on gloves and opening the package

a. Put on gloves



b. Open package



Step 5. While holding the square portion of the device. Place the sponge inside the person's mouth and against the inside of the person's cheek. Swab the inside of the cheek for 15 seconds. Sufficient pressure should be applied to see a bulge on the exterior of the cheek where the sponge is in contact on the inside of the cheek.



Step 6. Next pull the square cartridge to expose the card with the pink square. Fold the sponge so that it is in contact with the pink area of the card. The cartridge can then be closed.



Step 7. Complete the barcode envelope by adding the person's SID and the last name of the person from whom the sample was collected.

1100007 76

MUST HAVE

SUBJECT IDENTIFIER (SID) 456 12345

OFFENDERS LAST NAME Doe

Step 8. On the mailing envelope, circle arrest or conviction. Add the submission form and the barcoded envelope with the collection device to the mailing envelope. Seal the mailing envelope and return to the DNA Databank.

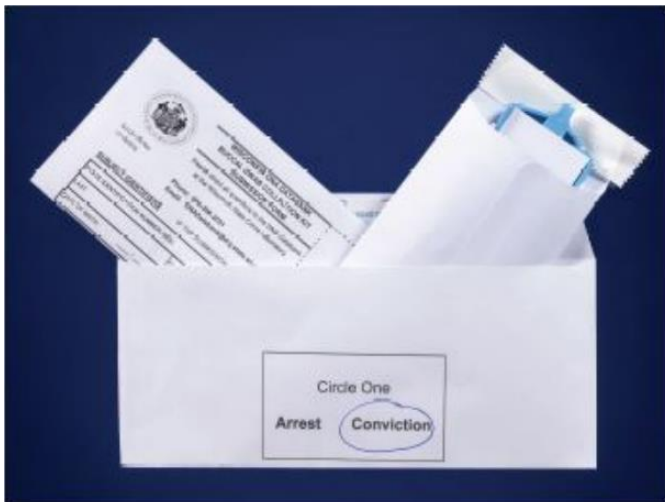

Chapter 9

Firearms & Ammunition

Information here is intended to assist the investigator in the recognition, evaluation, marking, packaging, and transmittal of firearms exhibits and related items to the Laboratory.

I. General Considerations

When requested, the Laboratory will process firearms exhibits and related items for fingerprints, DNA and trace evidence as well as the possible determinations listed in Table 9-1.

All exhibits should be properly inventoried. Record the description of the item, source, case number, item number, initials of person collecting, and the date and time collected. Sketch the area of recovery, indicating relative positions in feet and inches between exhibits and fixed objects, and supplement with photographs (*see Chapter 5 - Crime Scene Sketch*).

It is often possible to restore manufacturer's serial numbers, property marks, or other die-stamped markings which have been removed, altered, or obliterated on firearms (and other metallic objects such as tools, plates, and bicycles).

Firearms and fired ammunition may be delivered to the Laboratory in person or via parcel post, certified mail, or United Parcel Service (UPS).

All firearms must be shipped unloaded to the Laboratory with a marking on the package exterior indicating the firearm is unloaded. An evidence transmittal form should be sealed in an

envelope attached to the outside of the package. Indicate what kinds of examinations are requested, e.g., DNA, Trace Evidence, Identification, etc.

Firearms or other metal objects recovered from water (or nonflammable liquid) should immediately be placed in a container of the same liquid, completely submerged. When in a liquid, the oxidation process is considerably retarded minimizing change.

II. Marking of Firearms

Use extreme care in marking recovered firearms for purposes of identification. A reinforced identification tag may be attached to the trigger guard in front of the trigger.

Mark the tag with appropriate identifying data, including the serial number and description of the firearm, source, case number, item number, initials of collector, and the date and time collected.

III. Marking of Bullets, Fragments, Cartridge Cases, Shotgun Shells, Pellets, and Unfired Ammunition

All firearms and firearm related items should be handled with the assumption they will be fingerprinted or sampled for DNA. Therefore, only the packaging should be marked. In this way the possibility of damage, loss or contamination of trace evidence or DNA and destruction of possible fingerprints is greatly diminished. These items should not be packaged in cotton or sealed in plastic.

All packages should be properly sealed, with initials of collector over the seal, and marked with accompanying information such as the description of the item, source, case number, item number, initials of person collecting,

and the date and time collected, as described in Table 9-2.

In situations where through-and-through penetration of the victim's body has occurred and the bullet is found on the floor, in walls, etc., bullets or bullet fragments should not be touched with bare fingers. A small piece of clean white paper may be slipped under the bullet, then folded and placed in a rigid container, and finally sealed and identified. This procedure minimizes the possibility that the recovering officer will contaminate traces of blood which may be present on the bullet. The above recommendations should also apply to shotgun pellets and wads.

**Table 9-1:
Possible Laboratory Determinations Resulting
from Firearms Unit Examinations**

Evidence Required by Laboratory	Possible Laboratory Determinations
Fired Bullet	Make, caliber, type of firearms from which each could have been discharged; type of propellant used in firing; manufacturer and designation as to type, caliber, etc.
Two or More Fired Bullets	In addition to the possible determinations listed for a single fired bullet, whether two or more were fired from the same firearm.
Fired Cartridge Case or Nutshell	Make, caliber, type of firearm in which each could have been fired; type of propellant used in firing; name of manufacturer and designation as to type, caliber, etc.
Two or More Fired Cartridge Cases or Shotshells	In addition to the possible determinations listed for a single cartridge case, whether two or more cartridge cases or shot shells were fired in the same firearm.
Fired Bullet and Suspected Firearm	In addition to the possible determinations listed for a single fired bullet, whether bullet was fired from suspected firearm.
Suspected Firearm, Ammunition, Scaled Photograph of Powder or Shot Pattern and/or Victim's Clothing	Approximate distance at which shot was discharged.
Shot Pellets and Wads	Size of shot, and gauge designation of wads.

**Table 9-2:
Instructions for Handling, Marking, and Shipping
Firearms Exhibits**

Exhibit	General Instructions	Descriptive Record to be Kept by Person Recovering
Firearms	Check for fingerprints. Remove magazine from auto loading firearms. Do not clean or fire. Do not operate mechanism except to unload. If loaded revolver, mark hammer position and sketch cartridge positions. See column on marking for identification.	A record of make model, type, caliber or gauge designation, serial and lot numbers. If a loaded revolver, draw a sketch indicating position of hammer and cartridges.
Fired Bullets	Every precaution should be taken to prevent loss of trace evidence or abrading or mutilating bullet surface in any way. Do not wash or clean.	Sketch showing relative position of fired bullets collected from scene. Transmit a copy of this information to the Laboratory.
Fired Metallic Cartridge Cases	Do not mark, mutilate, scratch, or nick head of case. See column on marking for identification.	Sketch showing relative position of cartridge cases collected from scene. Transmit a copy of this information to the Laboratory.
Fired Shot Shells	Do not mark, mutilate, scratch, or nick head of shot shell.	Sketch showing relative position of shot shells collected from scene. Transmit a copy of this information to the Laboratory.

Shot Pellets	Recover as many as possible. Do not mutilate in recovery.	Sketch showing relative position of shot pellets collected from scene. Transmit a copy of this information to the Laboratory.
Shot Wads	Recover as many as possible. Do not mutilate in recovery.	Sketch showing relative position of shot wads collected from scene. Transmit a copy of this information to the Lab.
Loaded Shells or Cartridges	If unfired ammunition is recovered in investigation, forward to Laboratory. If ammunition manufacturer's boxes are recovered, forward to Laboratory for latent print examination.	Sketch showing relative position of shells or cartridges collected from scene. Transmit a copy of this information to the Laboratory.
Shot or Powder Patterns	If on clothing send only the clothing that might contain powder, powder residues, or exhibit bullet or shot penetrations. If on skin, doors, walls, etc., consult Laboratory concerning scaled photographs.	Description and source of garment containing shot or powder patterns. Location and size of shot or powder patterns on walls, doors, or other immovable objects.

Exhibit	Packaging, Marking for Identification and Shipping to the Laboratory
Firearms	Attach an ID tag and mark tag with initials, case #, date and item #. Secure firearms and magazines to cardboard box or rigid container with fasteners. Package each cartridge separately in a cardboard box or rigid container and mark containers according to your sketch. Seal the package, initial the seal, and label each container with case #, date, item # and source. Forward to Laboratory along with the descriptive record.
Fired Bullets	Package each separately in cardboard slide box or rigid container. Do not put in envelope. Mark on the container the source of each bullet. Seal the package, initial the seal, and label each container with case #, date, item # and source. Forward to Laboratory along with the descriptive record.
Fired Metallic Cartridge Cases	Package each separately in cardboard slide box or rigid container. Seal the package, initial the seal, and label each container with case #, date, item # and source. Forward to the Laboratory along with the descriptive record.
Fired Shot Shells	Same as above
Shot Pellets	Same as above (all of the available fired shots can go in a single box)
Shot Wads	Same as above
Loaded Shells or Cartridges	Same as above
Shot or Powder Patterns	Place each individual air-dried item of clothing in a separate clean paper bag. Seal each bag, initial each seal and label each bag with case #, date, item # and source. Forward to the Laboratory along with the descriptive record.

Chapter 10

Footwear & Tire Impressions

Footwear and tire impression evidence are two of the most valuable pieces of evidence left at crime scenes, however, they are often overlooked. Care should be taken to protect the entry and exit paths of a suspect to search for potential footwear and tire impression evidence. If detected, protected, and properly collected, they can be crucial in linking a suspect, or a suspect vehicle to a scene. In some cases, footwear and tire evidence can lead to the identification of the particular known footwear or tire as having made the impression.

Even when suspect footwear is not available, a questioned impression from a crime scene can be submitted to the Wisconsin State Crime Laboratories for an investigative leads search which may provide the investigator with valuable leads such as the possible make and model of the footwear which left the impression.

NOTE: As of January 1, 2016, the Wisconsin State Crime Laboratories no longer accepts cases and evidence/standards for Tire Track Analysis. The FBI Crime Laboratory in Quantico has agreed to work Tire Track Analysis cases that would normally be sent to the Wisconsin State Crime Laboratories.

For more information on how to submit evidence to the FBI Crime Lab, please call the FBI at 703-632-8444 or visit <https://www.fbi.gov/file-repository/handbook-of-forensic-services-pdf/view>.

I. Requesting Footwear Comparisons

Footwear comparisons are typically conducted between a questioned impression and known footwear or standards taken from the known footwear.

A questioned impression may be only a small portion of a shoe and does not need to contain the entire length for a comparison to be made. The most important factors are the quality of the impression and proper photography of the impression prior to collection.

- Submit items of physical evidence (e.g., evidence items, casts, electrostatic lifts, powdered lifts, etc.).
- Submit scaled digital image files (preferably in TIFF or RAW format) of all questioned impressions, if possible.
- Submit the known footwear for comparisons as it was recovered (do not clean) & inform lab of the recovery date (see section VII below).
 - Suspects may have more than one pair of the same brand and model of footwear. All should be submitted for comparison.

II. Requesting Footwear Investigative Lead Searches

If no known footwear is located, a questioned footwear impression(s) can be submitted to the Wisconsin State Crime Laboratories for an investigative lead search. Potential footwear investigative leads can be located through a search of the SoleMate® FPX database, the Wisconsin State Crime Laboratories' footwear standard reference collection, as well as a number of online resources. A footwear investigative lead search can yield information about a shoe's possible make(s) and

model(s) which may provide the investigator with valuable leads that would otherwise go unknown.

If known footwear is later located, the known footwear and properly photographed images of the impression(s) can be submitted to the laboratory in your service area for a complete comparison.



Fig. 10-1 Use of SoleMate® FPX for a footwear investigative lead search.

III. Footwear & Fire Impression Overview

Proper collection and preservation of footwear and tire impression evidence is essential to capture the detail observed at the crime scene. The choice of collection technique is based on the type of impression.

Two-dimensional impressions are impressions on flat surfaces such as wood, tile, linoleum, or granite countertops. They are most commonly visible impressions made in a residue such as blood, dust, paint, etc., but may require physical or chemical enhancement for collection. **These types of impressions are first preserved through proper photography with a scale.**

The methods used to recover two-dimensional impressions are routinely determined by the surface of

the object on which they are deposited and the substance in which the impression was made:

Dry origin impressions – Impressions formed when the surface and residue are dry (e.g., impression in dust). These impressions can be collected using an electrostatic lifting device, Stat-Lifts, or gel lifts (see section V below).

Wet origin impressions – Impressions formed under wet conditions including blood, grease, mud, etc. These impressions may be enhanced using chemical processing methods which are generally done in a laboratory setting when possible.

Three-dimensional impressions are visible impressions in a medium such as sand, soil, snow, or other pliable materials. **These impressions are first preserved through proper photography with a scale** and then may be recovered with casting materials (see section VI).

IV. Locating Footwear & Tire Impression Evidence

A. Evaluating the Scene for Footwear & Tire Impression Evidence

Footwear and tire impressions can be found in many locations at a crime scene. When processing for these impressions, the following should be considered:

- What is the likely path(s) that the suspect(s) took at the scene?
- Will the location of these impressions be probative to the investigation?
- Is it possible to reasonably differentiate the impressions of the suspect(s) from those of individuals who had legitimate access to the scene?

This evaluation process can save valuable time at a crime scene and at the Laboratory, allowing time and resources to be directed toward items of evidentiary value.

Deciding what to process within the scene and what evidence to collect should be done systematically. Try to reconstruct the suspect's movements outside and inside the scene if possible. Determining the following may also be helpful in locating valuable evidence linking the suspect to the scene:

- Points of entry and exit – doors, door frames, doorknobs, windows, screen and window frames, broken glass, or tools used to gain entry
- Points of attack – areas where items have been disturbed, damaged, or removed

B. Processing at the Scene vs. Submitting to the Laboratory

The question, "Can the evidence be collected, or must it be processed at the scene?" is a particularly important element to effective crime scene management. While it is not required to collect evidence for future processing, it is a practical recommendation to avoid being overwhelmed at the scene.

Collecting evidence at the scene for future processing may also provide:

- Access to specialized equipment and materials to enable sequential processing in order to maximize results.
- Time and resources to effectively complete a full examination.
- A more conducive work environment for evaluating and examining evidence, including preserving potential DNA evidence.

All impression evidence should be properly photographed prior to any attempts of collection. See *Chapter 3 - Forensic Photography, for detailed instructions.*

- Always include a scale when taking photographs of impressions to be used for examination. The scale should be placed on the same plane (at the same depth) as the impression.
- All impressions should be photographed with a scale prior to attempting to lift them due to the possibility of damage and/or incomplete lifting. Both the lifts and the images should be submitted to the laboratory for analysis.

All items collected for future processing should be handled carefully as even gloved hands and improper packaging can destroy impressions or dislodge other evidence. If DNA is a consideration, be sure to change gloves regularly. Items collected should be packaged following the recommendations outlined in Chapter 1.

If items have been processed prior to submission to the laboratory, information regarding what type of processing was performed should be provided with the evidence.

C. Visual Exams

Nondestructive visual examinations should always be done prior to processing, casting, or lifting. The use of a magnifier aided by oblique lighting with a flashlight can facilitate the discovery of visible footwear or tire impressions.

Visual exams can also facilitate the discovery of other evidence not readily seen by casual observation: trace materials, hairs, fibers, biological stains, etc.



Fig. 10-2 Use of a flashlight for a visual exam.

V. Two-Dimensional Impressions

A. Electrostatic Lifting Device

Electrostatic lifting devices are available from most forensic supply vendors and can be used to collect two-dimensional impressions composed of dust or dry, light, particulate residue from floors, walls, papers, and a variety of other surfaces.

Electrostatic lifting should be done prior to other lifting techniques.

NOTE: Scaled, comparison quality photographs should be taken of all electrostatic dust lifts prior to packaging due to the fragile nature of dust impressions (*Chapter 3 - Forensic Photography*).

The instructions listed below are general guidance for using an electrostatic lifting device. Follow the manufacturer's instructions for properly using a particular device.



Fig. 10-3 Proper placement of electrostatic lifting device.

1. Take comparison quality photographs of the impression. *See Chapter 3 - Forensic Photography.*
2. Cut a piece of clean lifting film to cover the impression, allowing an appropriate amount of excess in all directions.
 - a. On horizontal surfaces the film is placed over the impression with the Mylar (black) side down.
 - b. On vertical surfaces the film is placed over the impression with the Mylar (black) side down and held in place by taping the corners.
3. Position the grounding plate 1 – 2 inches from the edge of the lifting film.
4. Ensure the unit is properly grounded per the instructions of the unit. Care must be taken when the impression is on a metal surface.
5. While the device is off, place the high voltage probe on the metallic surface of the lifting film.
6. With the device set at the lowest output voltage, turn on the unit. Slowly increase the voltage until the lifting film has been “pulled down” to the surface or until the unit reaches its highest setting.
7. Use a clean ink roller to smooth out the film and remove any wrinkles or air bubbles.
8. Once sufficient contact has been achieved between the film and the substrate, turn down

- the current and turn off the device and allow the current to dissipate for a few seconds.
9. Carefully remove the film from the surface.
 10. Secure the lifting film (impression side up) with tape to the inside of clean, shallow box, or any other appropriate container that prevents anything from coming into contact with the lifting film. DO NOT fold the film and DO NOT package in plastic.
 11. Electrostatic lifting can be done multiple times on the same impression using clean film for each lift. Often the first lift will clean up the background dust and the subsequent lift(s) will better capture the impression.

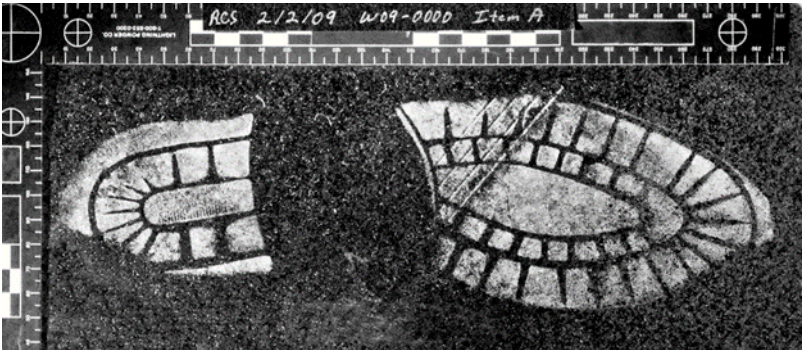

Fig. 10-4 Photograph of an electrostatic lift.

B. Stat-Lift™

Stat-Lift™ is a commercially available lifting material for collecting two-dimensional dust or dry, light, particulate residue impressions on a variety of surfaces.

NOTE: Scaled, comparison quality photographs should be taken of all Stat-Lifts™ prior to packaging due to the fragile nature of dust impressions (*see Chapter 3 - Forensic Photography*).

1. Take comparison quality photographs of the impression. See Chapter 3 - Forensic Photography.
2. Remove the white paper backing from the Stat-Lift™ (see Fig. 10-5).
3. Gently place the film over the impression using the side which was in contact with the backing paper.



Fig. 10-5 Removal of backing paper from Stat-Lift™.

4. Holding the film in place to prevent slippage, lightly smooth or press the Stat-Lift™ onto the surface to remove any wrinkles or bubbles. *Note: Care should be used to prevent slippage of the Stat-Lift™ because it can slide freely.*
5. Carefully remove the film from the surface (see Fig. 10-6).
6. To avoid possible fading/gradation, Stat-Lift™ should be photographed as soon as possible with a scale and oblique light.

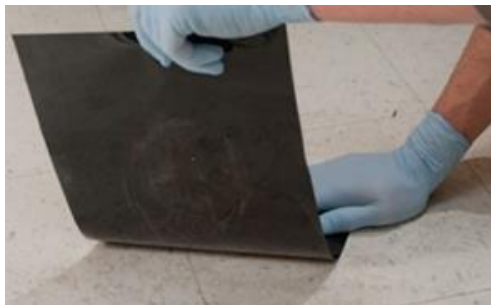

Fig. 10-6 Careful removal of Stat-Lift™ from surface.

7. Use caution when handling and packaging the lift to avoid destroying the dust impression.
8. Secure the lift (impression side up) with tape to the inside of a clean, shallow box, or any other appropriate container that prevents anything from coming into contact with the lifting film. **DO NOT** fold the lift and **DO NOT** package in plastic.
9. Additional Stat-Lifts™ can be used on the same impression. Often the first lift will clean up the background dust and the subsequent lift(s) will better capture the impression.

C. Gelatin Lifters

Gelatin lifters are an adhesive lifting device which can be used on almost any visible two-dimensional dust or dirt impression. In addition, gelatin lifters can be used to lift previously wet impressions or impressions developed with fingerprint powder. Gelatin lifters are available in white, black, and transparent and are available in a variety of sizes. Choose a lifter of contrasting color to the impression for optimal results.

NOTE: Whenever possible, attempt to lift the impression with an electrostatic lifting device or Stat-Lift™ prior to a gelatin lifter for best results.

NOTE: Scaled, comparison quality photographs should be taken of all gelatin lifts prior to packaging due to the

fragile nature of dust impressions (see *Chapter 3 - Forensic Photography*).

1. Take comparison quality photographs of the impression. See *Chapter 3 - Forensic Photography*.
2. Cut the gelatin lifter to the size of the impression.
3. Remove the clear cover.
4. Gently place the gelatin lifter over the impression with the adhesive side down. (see *Fig. 10-7*).



Fig. 10-7 Careful placement of gelatin lifter on surface.

5. Carefully smooth or press the gelatin lifter onto the surface without moving the lifter, ensuring good contact with the surface.
6. Allow the gelatin lift to remain in contact with the surface for a minimum of two minutes.
7. Carefully peel back the gelatin lifter from the surface.
8. To avoid possible fading/gradation, gelatin lifts should be photographed as soon as possible with a scale and oblique light.
9. Carefully replace the protective cover on the gelatin lift.
10. An examination of the impression and the surface should be made to determine if it can be powdered and/or re-lifted.

VI. Three-Dimensional Impressions

A. What to Cast

While it is preferential to cast all three-dimensional footwear and tire impressions at a scene, it may not always be possible. If it is not feasible to cast all impressions, care should be taken to cast the best footwear and tire impression evidence present. Close-up visual examinations of each impression should be conducted to determine which impressions exhibit the best clarity of detail. Oblique lighting from all four sides of each impression can also assist in conducting these visual examinations. Those impressions having the best detail should be marked and preserved for future casting.

If there are a large number of impressions at a scene, at minimum, the following should be cast:

- The best quality full footwear impression for each outsole design (left & right shoe).
- One full tire impression for each tire track present (left front, left rear, right front, and right rear in segments).
- Additional partial impressions with good detail and clarity to ensure that the most detail is collected.

DO NOT remove any debris embedded in the impression, as this may damage the impression. If there is any debris that appears to have “fallen in” to the impression it can be removed **after** the impression is first photographed; additional photographs should also be taken after removal of the debris.

NOTE: Scaled, comparison quality photographs should be taken of all three-dimensional impressions prior to casting due to the fragile nature of dust impressions (see *Chapter 3 - Forensic Photography*).

NOTE: These following suggested methods are not all-encompassing and there are a wide variety of products available for casting footwear and tire impressions. If you have any questions or would like any additional information or assistance, please contact the Wisconsin State Crime Laboratories.

B. Dental Stone Casting Procedures in Dirt/Sand

Dental stone can be used to cast footwear/tire impressions in sand, dirt, or snow. In order to properly cast a footwear/ tire impression using dental stone, thoroughly evaluate the substrate, the condition of the substrate, and the environmental conditions.

Dental Stone Casting Materials:

- Casting material (e.g., dental stone)
- Gallon-size zip-top plastic bags
- Water: approximately 4-6 oz. of water per pound of dental stone
- Scissors to cut open a bag, if necessary
- Object to deflect the casting material when pouring into the impression (large spoon, paint stir stick, etc.)
- Aerosol fixative to help stabilize the impression before casting (e.g., hairspray or Snow Print Wax™)
- Contrasting Spray (gray primer or Snow Print Wax™)
- Forming material (cardboard or metal landscape edging) to frame the impression if it is on a steep angle
- Box or cover to protect impression from weather
- Bowl or bucket if using bulk dental stone
- Stick or spoon for mixing bulk dental stone
- Permanent marker to "mark" the cast
- Cardboard box for packaging

Types of Dental Stone



Fig. 10-8 Pre-measured & bulk dental stone.

Dental stone material can be purchased in premeasured zip-top plastic bags or in bulk amounts. While premeasured bags will be sufficient to cast most footwear impressions, bulk dental stone is often more convenient for casting tire impressions.

Premeasured Dental Stone

Bags of premeasured dental stone (generally 2 pounds) are available from most forensic suppliers. The primary benefit of the premeasured dental stone is the ability to mix the dental stone in the bag. Premeasured bags of dental stone are easily stored in a scene processing kit along with spare gallon size plastic zip-top bags in the event that a premeasured bag of dental stone leaks during the mixing process.

Bulk Dental Stone

Bulk dental stone can be measured into gallon size zip-top plastic bags, bowls, or buckets. The size of the bowl or mixing container used can be determined by the size of the impression being cast. One large batch may be used to cast several smaller impressions if done in quick succession. The disadvantages of using bulk dental stone are the space required to maintain the additional equipment and the clean up after use.

Bulk Dental Stone Amounts (Approximate):

- 1.5 to 2 pounds for an average footwear impression
- 3 to 4 pounds for one segment of an average tire impression (complete tire rotation is ~ 3 segments)

General Procedure for Mixing Dental Stone

NOTE: Do not begin mixing casting material until you have all the materials you need.

Dental stone typically requires 4 to 6 ounces of water per pound of powder to make a mixture the consistency of pancake batter. While these are the recommended amounts, the actual amount of water needed can vary based on the temperature of both the water and the environment. *Dental stone should flow freely when poured but should not be watery or clumpy.*

Mixing Dental Stone in a 2-pound Premeasured Bag:

NOTE: An extra zip-top plastic bag can be placed around the premeasured bag to catch any leakage when mixing.

1. Add approximately 9 ounces of water to start; it is best to start with less and add more, as needed. *See Section C (Casting in Snow and Ice) below for specific instructions about dental stone casting of snow/ice impressions.*
2. Gently mix the contents of the bag for a **minimum** of 3-5 minutes so that the powder can thoroughly absorb the water; most commercially purchased premeasured bags have colored dyes that will dissipate as the contents mix.

3. Make sure that all of the dry material is thoroughly mixed, paying specific attention to the corners of the bag.
4. If the consistency is too thick, add more water; if it is too thin, add more powder.
 - a. Thinner is generally better.



Fig. 10-9 Mixing dental stone in a zip-top bag.

1. Place dental stone (approximately 1.5 to 2 pounds per footwear impression & 3 to 4 pounds per tire impression) in a bowl, bucket, or gallon-size Ziploc bag.
2. Slowly add the appropriate amount of water to the dental stone (approximately 4 to 6 ounces per pound of powder) to bucket or bowl; it is best to start with less and add more, as needed. *See Section C (Casting in Snow and Ice) below for specific instructions about dental stone casting of snow/ice impressions.*
3. Stir continuously for a **minimum** of 3-5 minutes to ensure that it is thoroughly mixed, and all of the dry material is incorporated into the mixture.
4. If the consistency is too thick, add more water; if too thin, add more powder.
 - a. Thinner is generally better.

Casting Dry Sand/Soil Impressions:

NOTE: Never pour the dental stone mixture directly into the impression!

1. Place a scale on the same plane (at the same depth) as the impression to be cast. Note: Avoid disturbing the impression!
2. Take comparison quality photographs of the impression. *See Chapter 3 - Forensic Photography.*
3. Place a form around the impression if it is on a steep angle (*see Fig. 10-10*).
4. Prepare the dental stone mixture as described above.
5. For fragile impressions in fine substrates (e.g., sand), an aerosol fixative may be applied by misting over the impression and allowing the fixative to fall into the impression. (*See Fig. 10-10*).

NOTE: Avoid spraying directly into the impression; rather allow a fine mist to drift into the impression.



Fig. 10-10 Use of a fixative & a form.

6. Carefully pour the casting material at the highest point on the ground **OUTSIDE** of the impression and direct the flow into the impression.
7. Continue to fill the impression by consistently pouring **onto existing casting material** for the length of the impression until the entire

impressed area is filled evenly with at least 1 inch of casting material. The newly poured dental stone **should not** strike the impression directly (see Fig. 10-11).

- a. Another option is to carefully pour the casting material onto an object such as a large spoon or paint stirrer to deflect the force of the dental stone and avoid damaging the impression (see Fig. 10-12).



Fig. 10-11 Pouring dental stone into an impression beginning at the highest point outside the impression. Note that the dental stone is poured onto existing dental stone and not onto the impression itself.

8. Allow the cast to dry completely, approximately 30-60 minutes; drying time may be longer in colder temperatures.
9. Once the cast is sufficiently hardened, mark it with the necessary identifying data (*see section E: Marking and Packaging Casts below*).
10. Loosen the soil around the outside of the cast and gently remove it. **Handle the cast very carefully because it is fragile and may break easily.**
- 11. Do not attempt to clean off the cast after removal.**
12. Package the cast properly (*see section E: Marking and Packaging Casts below*).



Fig. 10-12 Pouring dental stone using a deflector.

Casting Wet Soil/Submerged or Partially Submerged Impressions (Dry Powder Method):

NOTE: Never pour the dental stone mixture directly into the impression!

1. Place a scale on the same plane (at the same depth) as the impression to be cast. Note: Avoid disturbing the impression!
2. Take comparison quality photographs of the impression. *See Chapter 3 - Forensic Photography.*
3. Place a form around the impression if it is on a steep angle and/or to contain the casting mixture (*see Fig. 10-13*).
4. Remove any standing water from the impression, if possible, without disturbing the impression.
5. Sift small amount of dry dental stone into the standing water. Water will wick to the top of the dental stone; re-apply sifted dental stone until all standing water is absorbed.
6. Prepare the dental stone mixture as described above.
7. Carefully pour the dental stone mixture over the sifted dental stone to complete the cast.
8. Allow the cast to dry completely, at least 60 minutes; care should be taken not to remove the

cast too early as the moisture content of the soil may delay the drying.

9. Once the cast is sufficiently hardened, mark it with the necessary identifying data (*see section E: Marking and Packaging Casts below*).
10. Loosen the soil around the outside of the cast and gently remove it. Handle the cast very carefully because it is fragile and may break easily.
11. Do not attempt to clean off the cast after removal.
12. Package the cast properly (*see section E: Marking and Packaging Casts below*).



Fig. 10-13 Casting form placed around a submerged impression.

C. Casting in Snow and Ice

NOTE: Impressions in snow and ice should always be a first priority at a crime scene; they are extremely perishable! Cover the impression until casting to protect it from sun, snow, etc.

Dental stone, melted sulfur, Snow Print Plaster, and SnowStone™ are methods for casting footwear and tire impressions in ice and snow. Because heat is generated by the dental stone as it sets up, it is strongly recommended that one or more layers of Snow Print Wax™ or gray primer spray be added to the impression first to act as a buffer.

Dental Stone Casting of Snow/Ice Impressions:

NOTE: Extremely cold water is preferred when using dental stone to cast an impression in snow; in order to further cool the casting material, a small amount of snow can be added to the dental stone mixture in place of water.

1. Place a scale on the same plane (at the same depth) as the impression to be cast. Note: Avoid disturbing the impression!
2. Take comparison quality photographs of the impression. *See Chapter 3 - Forensic Photography.*
3. Optional: Lightly spray five to six layers of Snow Print Wax™ or gray primer over the impression. Avoid spraying directly into the impression, rather allow a fine mist to drift into the impressions. Allow to dry and repeat as needed. (*see Fig. 10-14 & 10-15*).
 - a. Re-photograph the impression using proper photography techniques after the application of each additional layer.
4. Place a form around the impression if it is on a steep angle (*see Fig. 10-10*).
5. Prepare the dental stone mixture as described above using snow and/or very cold water.
6. If there is excess moisture, such as in wet snow conditions, sift three layers of dental stone powder over the impression. The first layer should be sifted slowly and evenly to absorb the moisture from the snow. Only sift enough to absorb the moisture.
7. Carefully pour the casting material at the highest point on the ground OUTSIDE of the impression and direct the flow into the impression.
8. Continue to fill the impression by consistently pouring onto existing casting material for the length of the impression until the entire impressed area is filled evenly with at least 1 inch of casting material. The newly poured dental

stone **should not** strike the impression directly (see Fig. 10-11).

- a. Another option is to carefully pour the casting material onto an object such as a large spoon or paint stirrer to deflect the force of the dental stone and avoid damaging the impression (see Fig. 10-12).
9. Allow the cast to dry completely, at least 60 minutes or more in cold weather; care should be taken not to remove the cast too early as the moisture content of the soil may delay the drying. The cast may need to be covered while drying to protect it from the sun or additional snow, as well as to prevent the casting material from freezing.
10. Once the cast is sufficiently hardened, mark it with the necessary identifying data (see section E (Marking and Packaging Casts) below).
11. Loosen the soil around the outside of the cast and gently remove it. **Handle the cast very carefully because it is fragile and may break easily.**
12. **Do not attempt to clean off the cast after removal.**
13. Package the cast properly (see section E (Marking and Packaging Casts) below).



Fig. 10-14 Misting a light layer of Snow Print Wax™ onto the impression.



Fig. 10-15 Impression sprayed with Snow Print Wax™ which enhances the detail of impression and creates a buffer for the dental stone.

D. Sulfur Casting

Caution: This technique requires the user be familiar with safety issues regarding the use of sulfur (see sulfur SDS for additional information). The melting of sulfur should be done outside in a well-ventilated area while wearing a dust/mist respiratory mask to prevent the inhalation of sulfur fumes. Adequate ventilation and proper temperature control can also reduce the risk of igniting melting sulfur.

Sulfur Casting Materials:

- Sulfur powder, prill (pellets), or sulfur cement
 - ~5 pounds for an average footwear impression
- Heating device: electric heating mantle or hot plate
- One-gallon unlined paint can or 2-3 quart heavy port
- Large metal spoon
- Thermometer: infrared works best
- Metal tongs & heat-proof gloves to handle hot materials
- Dust mask or respirator
- Aerosol fixative to help stabilize the impression before casting (e.g., hairspray or Snow Print Wax™)
- Contrasting Spray (gray primer or Snow Print Wax™)
- Form (cardboard or metal landscape edging) to frame the impression if it is on a steep angle
- Box or cover to protect impression from weather
- Permanent marker to "mark" cast
- Cardboard box for packaging

Impressions being cast with liquid sulfur do not require a buffer layer of Snow Print Wax™ to protect them from the heat. However, a light application of Snow Print Wax™ or gray primer spray can be used to enhance the detail in the impression for photography.

Framing of the impression should be considered as liquid sulfur is thin and free flowing. Sulfur does tend to solidify on contact with ice and snow, which will help restrict its movement.

General Procedure for Sulfur Casting

NOTE: Prepare sulfur casting mixture in a well-ventilated area. Always use a dust mask or respirator and gloves when working with sulfur.

NOTE: Sulfur casts are very fragile and can easily break; sulfur cement casts are less fragile.

1. Place a scale on the same plane (at the same depth) as the impression to be cast. Note: Avoid disturbing the impression!
2. Take comparison quality photographs of the impression. *See Chapter 3 - Forensic Photography.*
 - a. Optional: Lightly spray five to six layers of Snow Print Wax™ or gray primer over the impression. Avoid spraying directly into the impression, rather allow a fine mist to drift into the impressions. Allow to dry and repeat as needed (*see Fig. 10-14 & 10-15*).
 - i. Re-photograph the impression using proper photography techniques after the application of each additional layer.
3. Place a form around the impression if it is on a steep angle (*see Fig. 10-10*).
4. Add approximately 5 pounds of sulfur powder, prill sulfur, or sulfur cement to an unlined paint can or a heavy pot in/on a heating device (*see Fig. 10-16*).



Fig. 10-16 Heating mantle with one-gallon unlined paint can.

5. Carefully melt the sulfur while constantly stirring and monitoring the temperature with a thermometer (~10-15 minutes).

- a. Sulfur melts at approximately 115°C and must be kept below 170°C to prevent burning or ignition.
 - b. Sulfur cement melts at approximately 110°C and must be kept below 187°C to prevent burning or ignition.
 - c. The sulfur should slowly turn from a yellow solid to a translucent amber liquid.
 - d. If the temperature of melted sulfur exceeds 160°C, it will become a dark, thick syrup at the bottom of the can. This is a sign that sulfur has become too hot and that the temperature should be lowered immediately.
6. Once all the sulfur has melted, turn off the heat source.
 7. Cool the melted sulfur by continuously stirring it until crystals start to form on the surface of the liquid. (see Fig. 9-17).



Fig. 10-17 Cooling sulfur

8. When it appears that crystals have formed throughout the liquid, carefully pour the liquid sulfur outside the perimeter of the impression, allowing the mixture to flow into the impression. Ensure the impression is completely filled and/or covered evenly.
 - a. Additionally, a deflector (e.g., metal spoon) can be used when pouring the sulfur to avoid damaging the impression. (see Fig. 10-18).



Fig. 10-18 Sulfur mixture is poured into the footwear impression using a deflector (metal spoon).

9. Allow the cast to cool for at least 20-30 minutes, or until completely set; a sulfur cast will lighten in color as it cools. (see Fig. 10-19).
10. Due to the extremely fragile nature of sulfur casts, it is recommended that an $\sim 1/2$ " layer of dental stone is poured over the back of the cooled sulfur cast to reinforce it prior to lifting (see Fig. 10-20).
 - a. Ensure the dental stone does not pour around the edges of the cast and into the impression underneath.
11. Once the cast is sufficiently hardened, mark it with the necessary identifying data (see section E: *Marking and Packaging Casts below*).
12. Loosen the snow around the outside of the cast and gently remove it; warm water may also be used if the cast is frozen to the ground. Handle the cast very carefully because it is fragile and may break easily.
13. Do not attempt to clean off the cast after removal.
14. Package the cast properly (see section E: *Marking and Packaging Casts below*).



Fig. 10-19 Sulfur cast which has begun to harden.



Fig. 10-20 Sulfur cast with dental stone reinforcement.

General Procedure for Snow Print Plaster & SnowStone™

Follow the manufacturer's directions listed on the packaging

E. Marking & Packaging Casts

Allow the cast to remain undisturbed for a sufficient amount of time to harden prior to marking or lifting it from the surface. Drying times will be affected by the consistency of the casting material, the humidity, the moisture content of the ground surface, and the air temperature (e.g., wet or colder conditions may require additional time to set). To be certain a cast is ready to be lifted, scratch the back of it with your fingernail and allow it to set longer if you can easily inflict a scratch mark.

Once the cast hardens, mark the necessary identifying data on the back of the cast. At a minimum, this should include:

- case number
- exhibit number or location collected (when multiple casts are made)
- date
- initials of the person making the cast
- arrow pointing north to orient the cast

Casts should be removed using a gentle rocking motion to avoid breaking the cast. Casts that do not release readily may require the loosening of the dirt underneath the cast. A knife or other bladed object should be inserted into the dirt at an angle allowing the dirt 1" below the cast to be loosened. At no time should the bladed object come into contact with the cast.

Do not attempt to clean off the cast after removal. Only loose sand or soil may be carefully removed after the cast is completely dry.

Allow the cast to air dry for at least 24 - 48 hours before packaging.

To package casts, wrap each separately in thick paper or bubble wrap. Seal the cast in an appropriately sized box with enough packaging material to protect it from damage. Each cast should be sealed in a separate box. Casts should never be packaged in plastic.

VII. Collection of Footwear Standards

For a thorough examination, it is recommended that the actual known footwear be submitted to the laboratory for comparison. The known footwear should be submitted as it was recovered (do not clean) and inform the laboratory of the recovery date.

In the event that the collection of the known footwear is not possible, scaled images of the outsoles of the shoes can be submitted for comparison (See Fig. 10-21). Ensure that proper photography techniques are utilized (scale on the same plane as the sole of the footwear, camera lens parallel to the sole of the footwear, etc.) as described in Chapter 3, Forensic Photography.

It is recommended that known standards of family members, law enforcement employees, and other personnel present at the scene be documented for elimination purposes. Companies that carry fingerprint identification supplies provide products that can easily produce actual size (1:1) test impressions. Photography is also appropriate when proper photography techniques are utilized.

NOTE: Do not package the known footwear in plastic.



Fig. 10-21 Properly photographed image of a footwear outsole.

Chapter 11

Friction Ridge Impressions

Friction ridge detail from the fingers, palms, and feet has been a valuable method of personal identification in forensic science and criminal investigations for more than 100 years. One of the most significant benefits of this evidence is that it can establish an individual's presence at a crime scene or contact with an object. Friction ridge evidence is most significant when the person identified had no lawful presence where the print was found or no lawful contact with the object touched.

Questioned friction ridge detail (latent prints) can be compared with known standards in order to attempt to identify or exclude the individual as having deposited an impression. Additionally, unidentified friction ridge detail can be searched in the Wisconsin Automated Fingerprint Identification System (AFIS) and the FBI's Next Generation Identification (NGI) to attempt to identify the source of the impression.

I. Requesting Friction Ridge Impression Examinations

A questioned friction ridge impression may be only a small fragment and does not need to contain the entire finger, palm, or sole of a foot in order for a comparison to be made. The most important factors are the quality of the impression and proper photography of the impression prior to collection.

NOTE: For specific information on the submission of friction ridge evidence to the Wisconsin State Crime Laboratories, please see the [Evidence Submission Guidelines](#) on the Wisconsin State Crime Laboratories' website.

1. Submit items of physical evidence (e.g., evidence items, lifts, etc.).
2. Submit scaled digital image files (preferably in TIFF or RAW format) of all questioned impressions, if possible.
3. Submit known friction ridge standards of all individuals who are believed to have touched the evidence items (See Section V below)

II. Friction Ridge Impression Overview

Proper collection and preservation of friction ridge impression evidence is essential to capture the detail observed at the crime scene. The choice of collection technique is based on the type of impression:

Latent prints are prints that often require physical or chemical enhancement for collection. These types of prints are first preserved through proper photography with a scale, if possible. The processes used to recover latent prints are routinely determined by the surface of the object on which the latent prints are deposited and the condition of that surface. These surfaces can be divided into four general categories:

- Non-porous – surface does not absorb water: glass, metals, plastics
- Porous – surface absorbs water: paper, cardboard, wood
- Semi-porous – shiny surface which may absorb water: glossy papers, printed boxes
- Adhesive surfaces – surface with an adhesive side: tapes, labels, stamps

See sections III & IV below for processing and collection of latent prints.

Patent prints are visible prints typically resulting from a foreign substance such as blood, dirt, ink, paint, etc. These types of prints are first preserved through proper photography with a scale. Once these prints are captured photographically, these prints may be further enhanced using chemical processing methods which are generally done in a laboratory setting when possible.

Plastic prints are visible three-dimensional prints usually impressed into a medium such as dirt, clay, wax, soap, paint, etc. Plastic prints are first preserved through photography with a scale and then may be recovered with silicone-type casting materials. See a forensic materials supply company for these types of casting materials.

III. Locating Friction Ridge Impression Evidence

A. Evaluating the Scene for Friction Ridge Impression Evidence

Even though all objects at a crime scene could be viewed as a possible source of friction ridge detail, it would be impractical, if not impossible, to process everything. When processing for friction ridge detail, the following should be considered:

- Which objects were likely to have been touched by the suspect(s)?
- Were any objects left behind at the scene?
- Will prints on the object be probative to the investigation?

This evaluation process can save valuable time at a crime scene and at the Laboratory, allowing time and resources to be directed toward items of evidentiary value.

Deciding what to process within the scene and what evidence to collect should be done systematically. Try to reconstruct the suspect's movements outside and inside the scene if possible. Determining the following may also be helpful in locating valuable evidence linking the suspect to the scene:

- Points of entry and exit – doors, door frames, doorknobs, windows, screen and window frames, broken glass, or tools used to gain entry
- Points of attack – areas where items have been disturbed, damaged or removed
- Areas of restricted movement – narrow hallways, stairways and cluttered areas may result in inadvertent touching of walls, handrails, and other obstructions

B. Processing at the scene vs. submitting to the laboratory

The question, "Can the evidence be collected, or must it be processed at the scene?" is a particularly important element to effective crime scene management. While it is not required to collect evidence for future processing, it is a practical recommendation to avoid being overwhelmed at the scene.

Collecting evidence at the scene for future processing may also provide:

- Access to specialized equipment and materials to enable sequential processing in order to maximize results.
- Time and resources to effectively complete a full examination.
- A more conducive work environment for evaluating and examining evidence, including preserving potential DNA evidence.

All friction ridge impression evidence should be properly photographed prior to any attempts of collection. See *Chapter 3 - Forensic Photography, for detailed instructions.*

- Always include a scale when taking photographs of impressions to be used for examination. The scale should be placed on the same plane (at the same depth) as the impression.
- All friction ridge impressions should be photographed with a scale prior to attempting to lift them due to the possibility of damage and/or incomplete lifting. Both the lifts and the images should be submitted to the laboratory for analysis.

All items collected for future processing should be handled carefully as even gloved hands and improper packaging can destroy prints or dislodge other evidence. If DNA is a consideration, be sure to change gloves regularly. Items collected should be packaged following the recommendations outlined in Chapter 1 of this handbook.

If items have been processed prior to submission to the laboratory, information regarding what type of processing was performed should be provided with the evidence.

C. Visual Exams

Nondestructive visual examinations should always be done prior to processing or lifting. The use of a magnifier aided by oblique lighting with a flashlight can facilitate the discovery of visible prints.

Visual exams can also facilitate the discovery of other evidence not readily seen by casual observation: trace materials, hairs, fibers, biological stains, etc.



Fig. 11-1 Use of a flashlight for a visual exam.

The use of an alternate (forensic) light source (ALS) or portable laser may also be of benefit to visualize friction ridge impressions and other evidence before processing.

Friction ridge impressions observed during visual exams should be photographed **with a scale** (see *Chapter 3 - Forensic Photography*) prior to collection or using physical or chemical processing techniques. Additionally, the location of any friction ridge evidence observed during visual examinations should be documented.

D. Superglue Fuming

NOTE: Scaled, comparison quality photographs should be taken of all visible friction ridge impressions prior to processing (See *Chapter 3 - Forensic Photography*).

Superglue (cyanoacrylate) fuming is a highly effective technique for developing friction ridge detail on non-porous surfaces. Superglue fumes adhere to latent print residue and make the prints more durable and less likely to be damaged or obliterated. These developed prints can then be enhanced using powder or fluorescent dye stains. Superglue fuming is recommended before fingerprint powders are used.

The effectiveness of the superglue process is dependent on variables such as ambient temperature and humidity, the container being used to process the items, and the length of time the items are fumed.

The superglue process is a relatively simple technique. A typical setup is shown in Fig. 11-2. The equipment needed includes:

- an **airtight** chamber such as an aquarium
- superglue (pouches or liquid) – **make sure it contains cyanoacrylate** since some store brands do not
- hot water to increase humidity
- a hot plate (if using liquid superglue) and a non-melting container to hold the superglue (foil is recommended)
- a method of suspending items in the chamber

NOTE: SUPERGLUE FUMES ARE EXTREMELY DANGEROUS! Use this process only in well ventilated areas such as an exhaust hood or a large open area to avoid inhaling superglue fumes.



Fig. 11-2 Example of a typical superglue fuming chamber. (A) is a piece of wire from which items can be

suspended. (B) is a beaker of hot water. (C) is a mug warmer to heat liquid superglue on a piece of foil.

NOTE: If superglue pouches are used, the hot plate is not necessary

General Procedure for Superglue Fuming

1. Place the evidence into the chamber, making sure all surfaces of the items are exposed to the fumes.
2. Put superglue (on a hot plate if necessary) and water into an airtight chamber.
3. Monitor fuming development.
4. Properly ventilate the chamber before removing evidence.

Continuously monitor the superglue development of latent prints to ensure that the items are not over-processed. Depending on the size of the fuming container, items may be processed in as little as 5 minutes. Be sure to stop fuming once any indication of a white film is detected. A flashlight and a test print on a dark or shiny surface may help to visualize the development. It is always better to under-process than to over-process.

E. Latent Print Powders

NOTE: Scaled, comparison quality photographs should be taken of all visible friction ridge impressions prior to processing (*See Chapter 3 - Forensic Photography*).

Non-porous surfaces can be dusted with fingerprint powders to assist in locating and enhancing friction ridge detail.

NOTE: It is recommended that the nonporous items be processed with superglue (cyanoacrylate) prior to using any powders, if possible. The superglue process will

make impressions more durable and less likely to be damaged during shipping or transportation to the Laboratory. In addition, further processing with chemical techniques and ALS/laser examination to develop and enhance any latent prints that are present can be performed at the Laboratory. Fingerprint powder interferes with these chemical techniques if the item was not initially processed with superglue.

Either traditional or magnetic powder can be used on most non-porous surfaces. Powders should be applied using the following guidelines:

- Use black powder as often as possible; black powder can even be used on dark surfaces.
- Apply a very small amount of powder with a gentle, circular-type motion; it is best to **start with less powder** and add more powder as needed.
- Carefully follow the ridges with the brush; **do not brush back and forth across the ridges.**
- Evaluate the print continuously until the desired contrast is obtained.
- Stop processing if the print is showing any signs of damage or the contrast diminishes.
- Clean the developed print to remove excess powder and to provide maximum clarity of detail (*see Fig. 11-3*).

The following cleaning techniques can improve the quality and clarity of powdered prints by removing excess powder:

- Very carefully use a powder-free detail brush to follow the flow of the ridges of the print.
- Gently tap the item on its edge.



Fig. 11-3 Failing to clean a print before lifting can result in air bubbles and powder debris voids.

F. Porous & Semi-porous Surfaces

Porous items should not be processed with powders but should be collected for chemical processing. While it may be possible to develop prints using powders on some semi-porous items, **it is not recommended for optimal development.** Chemical techniques are available which may provide better results on these items. If you have any additional questions about porous and semi-porous items, please contact the Laboratory.

IV. Collection of Friction Ridge Impression Evidence

A. Photography

NOTE: Scaled, comparison quality photographs should be taken of all visible friction ridge impressions prior to processing, lifting, or packaging (*See Chapter 3 - Forensic Photography*).

Visible or powdered prints should always be photographed with a scale before attempting to lift them. Both mid-range and close-up photographs should be taken. Mid-range photographs document the location of the developed prints while close-up

photographs provide the needed detail for comparisons. Close-up photographs should be taken as follows:

- The camera must be mounted on a tripod, perpendicular to the friction ridge impressions
- Each print should be photographed individually, filling the viewfinder, with the scale increments present in the image (see Fig. 11-4)
- The scale should be placed on the same plane (at the same depth) as the print
- Friction ridge impressions should be photographed in a lossless format (i.e. TIFF or RAW).



Fig. 11-4 Measurement increments should be visible in the photo to show whether they are in mm, cm, or inches.

Refer to *Chapter 3, Forensic Photography* for more details on how to photograph impression evidence.

B. Lifting

Latent print lifts are primarily made with clear tape of various widths placed onto backing cards. Flexible tapes are generally the easiest to work with on most surfaces, but gel/rubber lifters, gel tapes, or casting materials such as Mikrosil may be used for rough or textured surfaces (see Fig. 11-5). When lifting from a difficult surface, a test lift can be attempted using an

area of the surface without an evidentiary print to determine what lift method may work best.

Choose a lifting material that will provide the best coverage and remove all of the print(s) from the surface. Whenever possible, simultaneous finger impressions and palm prints should be lifted together to assist in comparisons. If your lifting tape is not wide enough to cover a large section, overlap pieces of tape to cover the friction ridge impression(s), and lift them all together.

Multiple lifts of the same impression can be made if it can still be visualized after the first lift. This is especially true if the item has been processed with superglue first. The initial lift may clear away debris, improving detail in the impression, resulting in a second, better quality lift. When duplicate lifts are made, they should be clearly marked as such to avoid confusion during comparisons.

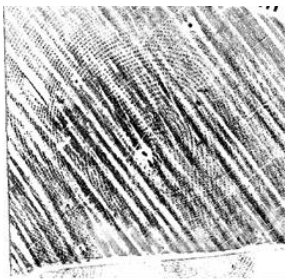

Figs 11-5, 11-6 Standard lifting tape on textured or rough surfaces (Fig. 11-5) can result in voids. Gel tapes, gel lifters, and casting materials (Fig. 11-6) which are more flexible can be used in an attempt to eliminate these voids.

NOTE: Lifting should be attempted ONLY after scaled photography.

Tape lifts should be placed on a transparent acetate sheet or a card of a contrasting color to the powder

used. Transparent sheets are strongly recommended when lifting prints that are difficult to see due to a lack of contrast, such as those dusted with white or grey powder.

General Procedure for Lifting

1. Pull a length of tape sufficient to cover the area to be lifted from the roll in a single motion.
 - a. The tape can remain attached to the roll for stability or can be cut from the roll if more flexibility is needed.
 - b. When cutting the tape from the roll, either before or after lifting, it is advisable to leave a leader for future use. One way to produce a leader is to fold over the end of the tape after each cut. Another method is shown in Fig. 11-7.

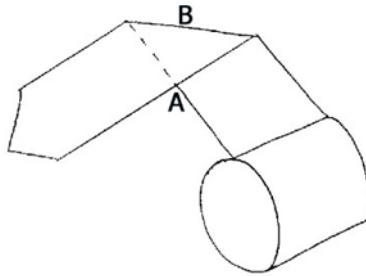

Fig. 11-7 Cutting the tape from A to B will leave a leader for the end of the roll and for the piece used for the lift.

2. Without covering the print to be lifted, align, and secure the end of the tape next to the print to ensure smooth contact with no buckling (see Fig. 11-8).

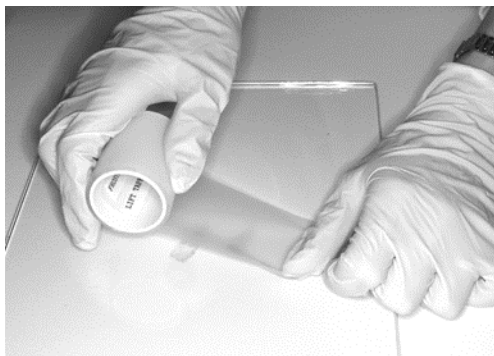

Fig. 11-8 While keeping the tape off the evidence, one end of the tape is anchored at a point beyond the latent prints to be lifted.

3. Holding the unsecured portion of the tape above the surface, slowly smooth the tape across the print(s) with your fingers until the entire area is covered (see Fig. 11-9). Minimize or eliminate any resulting air bubbles or debris voids by rubbing with the flat surface of your fingernail.

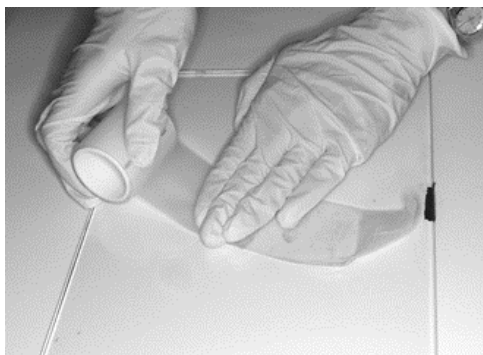

Fig. 11-9 Smooth the tape over the print(s) from one end to the other in a continuous motion eliminating air bubbles.

4. Carefully lift the tape from the item.
5. Using the same technique as in Steps 2 and 3 above, slowly smooth the tape across the backer.

NOTE: Do not discard any lift in which ridge detail is observed; submit all lifts to the laboratory for evaluation.

General Procedure for Marking a Lift

After making the lift, it should be immediately marked for identification purposes (see Fig. 11-10). The information recorded should include the following:

- Case number
- Date collected
- Item lift was collected from
- Name of individual making the lift
- A small sketch of the item on the back of the lift card with a mark orientating the location of the lift for future reference and court documentation

Date	Crime	Case No.
10/27/08	BURGLARY	99-774
Victim		
JOHN DOE		
Address of Incident		
100 MAINST.		
Location of Latent Prints Lifted		
FRONT DOOR, WINDOW, LOWER		
RIGHT		
Prints Lifted by:		ID No.
JRD		00100
Lightning Powder Company 1-800-852-0000		

↑
location of prints

Fig. 11-10 Information documented on the back of latent lift card.

Avoid placing circles or arrows on the lift tape to indicate where latent prints were observed. These

markings often cover prints of weaker contrast. However, you should "X" out any friction ridge detail known to be deposited on the tape by the person making the lift (see *Fig. 11-11*). Any other markings should be placed on the lifting card, not on the tape.



Fig. 11-11 "X" out any friction ridge detail known to be deposited on the tape by the person making the lift.

Contact the Latent Prints & Footwear Unit in your service area if you have any questions regarding the collection of friction ridge impressions.

C. Handling & Packaging Evidence

Evidence which will be submitted for latent print analysis should be handled as little as possible and in such a manner as to prevent the collector's prints from being placed on the object. Gloves should be worn during the collection process and care should be taken so as not to wipe away any latent prints, particularly on non-porous and semi-porous surfaces.

NOTE: It is possible to deposit latent prints through disposable (e.g., latex, nitrile) gloves, so all evidence

should be handled with extreme care even when wearing gloves.

General packaging guidelines to ensure the integrity of the evidence include the following:

- Secure large or potentially dangerous or fragile items with zip ties to prevent shifting and contact with other items or the interior of the packaging.
- Do not tightly wrap non-porous items as this may damage or destroy any latent prints.
- Air dry wet or damp items before packaging in paper. If an item is submerged in water, place it in a container with the same water for transport to the laboratory.
- Tape with exposed adhesive surfaces should be placed on acetate or wax paper, and then placed in a cardboard box.

V. Friction Ridge Impression Examinations

Friction ridge impression comparisons are typically conducted between a questioned impression and known standards taken from an individual. Additionally, questioned friction ridge impressions can be searched through the Wisconsin Automated Fingerprint Identification System (AFIS) and the FBI's Next Generation Identification (NGI) to attempt to identify the source of the impression.

A. Submission of Friction Ridge Standards

High quality, fully captured friction ridge standards are essential to allow a complete comparison with questioned impressions.

Friction ridge impressions recovered from items of evidence often come from the fingertips, sides of the fingers, the second or third joint areas of the fingers, or the palms. For this reason, it is always best to obtain comprehensive known prints for comparison. A properly

rolled ten print card should have all ten fingers and thumbs rolled nail to nail with minimal smears, along with plain (or flat) impressions at the bottom of the card (see *Fig. 11-12*). Similarly, a properly collected palm print should capture all areas on the palm including the writer's palms (sides of the palms) and the lower joints (see *Fig. 11-13*).

In some instances, major case print standards may be requested for friction ridge impression comparisons, in addition to a regular set of rolled fingerprint and palm print standards. These standards include the fingertips, side of the fingers, lower joints of the fingers, and the outer edges of both palms (writer's palms). Major case prints should always be taken for victims in suspicious deaths (see Section B below).



Fig. 11-12 Example of correctly rolled fingerprints.



Note that the writers palms are also included

Fig. 11-13 Example of correctly rolled palm prints, including writer's palms.

Elimination standards should be submitted for all individuals with rightful access to locations where latent print evidence is collected and who may have touched the evidence items (e.g., residents of the house, owners/drivers of a stolen vehicle, employees who handled items, law enforcement, etc.).

If original standards cannot be obtained, the laboratory may be able to obtain standards from the Crime Information Bureau (CIB) or the FBI if the full name, date of birth, State Identification (SID) Number or FBI Number are provided.

All submitted standards should be labeled with the identifying information of the subject as well as the date and initials of the individual recording the standards. These standards should be treated as evidence and should be packaged accordingly.

B. Collection of Major Case Prints

The purpose of major case prints is to record all of the friction ridge detail on the hands so that complete finger and palm print comparisons can be completed. This includes the fingers, fingertips, finger joints and edges of the fingers as well as the entire palm. **Major case prints should be taken from victims and suspects in all homicides, suspicious deaths, and as requested.**

Powder & Tape Method

Equipment needed:

- Black powder (traditional or magnetic)
- 1.5" clear flexible lifting tape (4" clear lifting tape can be used for the palms)
- Fingerprint brush (traditional or magnetic applicator)
- 8" x 10" or larger clear acetate sheets
- Permanent marker
- Scissors

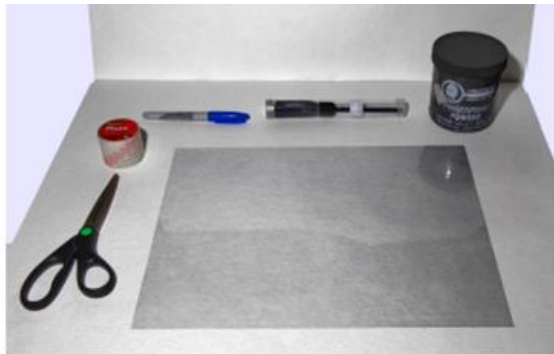

Fig. 11-14 Equipment needed for the powder & tape method.

General Procedure

1. Using the permanent marker, write the following information on the acetate sheet (see *Fig. 11-15*):

- Name of the individual being printed
- Date of birth of the individual being printed
- Agency case number
- Name of the person collecting the prints
- Date of collection
- The hand & finger positions of one hand

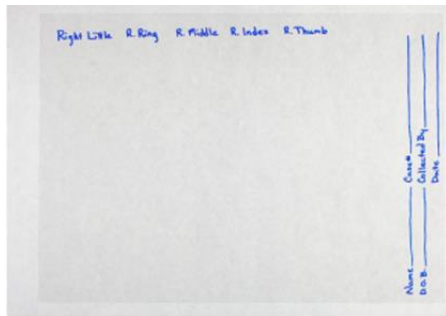

Fig. 11-15 Recording of finger information on acetate.

2. Flip the sheet of acetate over. The lifted ridge detail will be placed below the appropriate headings on the opposite side of the acetate as the writing (see *Fig. 13-16*).

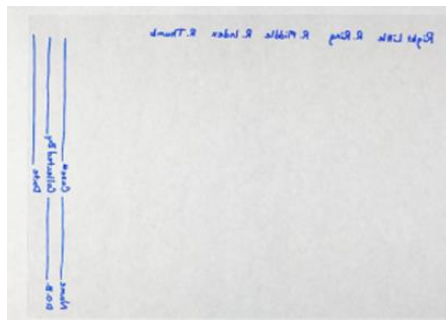

Fig. 11-16 Acetate flipped over.

3. Cut 10 piece of tape long enough to cover the entire length of each finger (*see Fig. 11-17*).



Fig. 11-17 Cut pieces of tape.

4. Apply a light coating of black fingerprint powder to the entire palmar surface of the hand, including the areas between the fingers and all edges of the palms (*see Fig. 11-18*). Note: It is easier to start with less powder & add more than it is to remove it if you start with too much.



Fig. 11-18 Lightly dust fingers with powder.

5. Adhere a strip of tape to the tip of the nail. Fold the tape over the top of the finger and smooth it down the length of the finger toward the palm (*see Fig. 11-19*).



Fig. 11-19 A lightly dusted finger with tape attached to tip of the nail and smoothed down the length of finger.

6. Release the top edge of the tape from the nail and smooth the edges of the tape into the tip and around the sides to cover all the ridge detail. Make sure to press the tape into all areas of the tip as it starts to fold (see *Figs. 11-20 & 11-21*).



Fig. 11-20 & Fig. 11-21 Tape is released from the nail & tape is smoothed around sides of finger.

7. Carefully lift the tape off the finger and place it in the correct finger position on the acetate sheet (on the opposite side of the writing) (see *Fig. 10-22*).



Fig. 11-22 Tape lifted from a finger is placed on the acetate sheet under the correct finger name on the opposite side of the writing.

8. Repeat steps 5-7 with rest of the fingers on that hand (see Fig. 10-23).



Fig. 11-23 Acetate with all five fingers from the right hand.

9. To record the palm, start by repeating steps 1 & 2 (see Fig. 10-24).

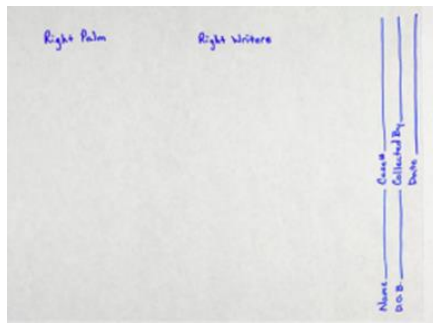

Fig. 11-24 Recording of palm information on acetate.

10.A. If using 1.5" tape, cut three pieces of tape long enough to cover the entire width of the palm. Starting at the writer's palm, place them horizontally across the palm (one at the top, one in the middle, and one at the base) ensuring the tape slightly overlaps.

- Make sure to start slightly above the palm on the joints of the fingers and go over the entire palm into the center and down past the bracelet creases of the wrist (see Fig. 10-25).
- Smooth the tape and press into the palm to ensure all friction ridge detail is recorded.



Fig. 11-25 Placing top piece of tape above the palm on the joints.

10.B. If using 4" tape, cut a piece of tape large enough to cover as much of the palm as possible. Starting at the writer's palm, place one end of the tape along the writer's palm (little finger side) & press it into the palm toward the thumb.

- Smooth the tape and press into the palm to ensure all friction ridge detail is recorded.
- Use a piece of 1.5" tape to slightly overlap onto the existing tape to ensure that all areas of the palm are covered, including the lower joints & the base of the palm (see Fig. 10-26).

- Smooth the tape over the entire palm to ensure the tape is pressed into the center of the palm.



Fig. 11-26 4" tape smoothed across palm.

11. *Carefully* lift the tape off the palm as one piece and place it on the acetate sheet (on the opposite side of the writing).
12. If the writer's palm was not captured repeat the procedure with the writer's palm (see Fig. 11-27).



Fig. 11-27 Recording of the full palm & writer's palm.

13. Review the lifts taken. If the ridge detail is not fully recorded, is too light, too dark, or unclear, take another lift of that area and place it below the first recording of the same area or place it where there is room and label it. For example,

if a second lift of the right ring finger is made, place the second lift below the first lift of the right finger on the acetate (see Fig. 11-28).



Fig. 11-28 Second recording of the right ring finger placed under the first recording of the right ring finger.

14. Repeat steps 1 – 13 with the other hand.
15. Package the acetate sheets in a heat-sealed plastic bag or an envelope that is large enough to ensure that the acetate does not bend or fold.

Ink Method

Equipment needed:

- Standard tenprint/palm print card (8" x 8") or other clean white recording surface
- Black printers' ink
- A roller for spreading ink on the fingers and hands
- A cylinder, 3" or more in diameter for rolling palms



Fig. 11-29 Equipment needed for the ink method.

General Procedure for Recording Fingers

1. The first step to taking major case prints is to roll a standard ten print card (see *Fig. 10-30*). Each finger should be rolled from nail edge to nail edge to obtain the entire width of the pattern area. Care should be taken to also include as much of the tip and the first crease as possible.

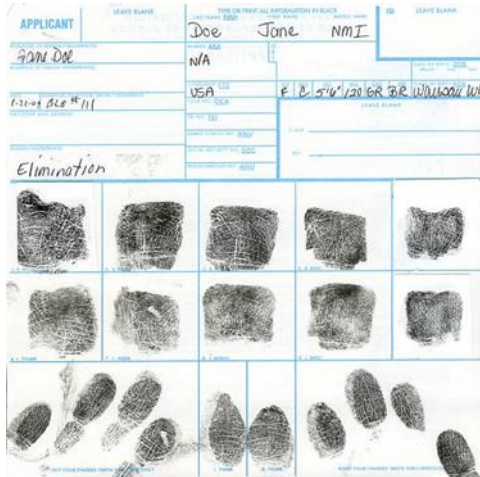

Fig. 11-30 Ten print card with properly recorded inked prints.

2. After the tenprint card has been properly recorded, the entire finger is then inked for recording the inner, middle, and outer edges, and the tip of each finger. This step will require the use of at least two 8" x 8" cards (see Fig. 10-31).
3. Starting with the thumb, the outer edge or side of the inked thumb is placed on the card and rolled 45° inward towards the middle.
4. The middle area of the thumb is then placed on the card next to the rolled outer edge.
5. The inner edge of the thumb is recorded in the same manner as the outer edge.
6. The thumb is then completed by recording the tip area, placing it on another sheet or above the previously recorded edge areas.
7. **Be sure to label each finger on the card and repeat the above procedure until all fingers have been clearly recorded.**

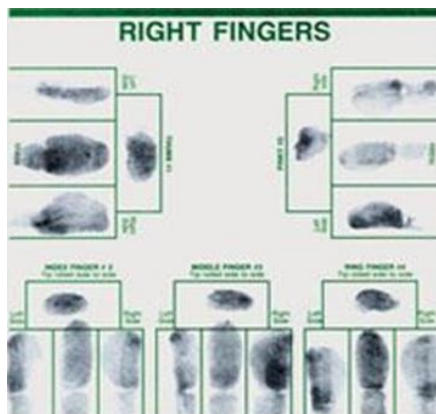

Fig. 11-31 Inner, middle, and outer edges & tips of right fingers & thumbs.

General Procedure for Recording Palms

1. Attach an 8"x8" card to the cylinder using rubber bands on each end to avoid movement during rolling.
2. Apply a thin layer of ink to the palm and fingers (see Fig. 11-32).
3. Beginning with the wrist area, roll the hand onto the 8" x 8" card attached to the cylinder. The wrist area of the palm is placed onto the bottom edge of the card and rolled gently backwards towards the body (see Fig. 11-33). A hand placed on the back of the palm, using a slight downward pressure, will help ensure the entire palm is recorded properly.



Fig. 11-32 Ink the palm and fingers with a thin uniform coat.



Fig. 11-33 Place the palm of the hand on the cylinder and roll the hand to the fingertips maintaining pressure on the hand.

4. The outer edge of the palm is then recorded on the card (see Fig. 11-34).
5. This process is repeated until all friction ridge detail is recorded clearly and legibly (see Fig. 11-35).



Fig. 11-34 The outer edge of the palm is recorded. A sheet of paper can be used to protect the rest of the document when recording the outer edges of the palm.



Fig. 11-35 Ridge detail of the palm is recorded from the base of the palm to the fingertips and the outer edges of the palm.

Inked Power & Tape



Fig. 11-37 (left) Example of inked recording.

Fig. 11-38 (right) Example of powder recording.

Benefits of the Powder and Tape Method over the Ink Method

- Less Time to complete than inked method.
- Limited clean up.
- Powder covers ridge detail more evenly.
- No rolling of fingers or palms to cause smearing.
- Gives greater detail in one recording.

C. Database Searches

Unidentified questioned friction ridge impressions can be searched through the Wisconsin Automated Fingerprint Identification System (AFIS) and the FBI's Next Generation Identification (NGI) to attempt to identify the source of the impression.

AFIS is an electronic repository of fingerprints and palm prints of known individuals maintained by the Wisconsin Department of Justice and NGI the FBI's national repository.

Questioned friction ridge impressions that are determined to be suitable for entry can be searched in AFIS and/or NGI. If a possible matching impression is found, the examiner performs a comparison of the questioned impression to the standard in the AFIS/NGI archive and determines if an identification can be made.

If a search does not result in an identification, the questioned impression can be registered in the AFIS and/or NGI Unsolved Latent File (ULF). As new fingerprint and palm print known standards are entered into AFIS and NGI, they are searched against each questioned impression stored in the ULF. The submitting agency will be notified via a report if a print registered in the ULF is later identified.

In the event the submitting agency should identify any new persons of interest associated with the case, the appropriate standards (fingers and/or palms) should be submitted to the laboratory for comparison with unidentified questioned impressions. Additionally, if a case that was submitted to the laboratory is closed, the agency should notify the laboratory so these prints can be removed from the ULF.

NOTE: Due to the nature of the AFIS/NGI systems, if a matching impression isn't generated from an AFIS/NGI search, that doesn't necessarily imply that the standard is not in the database. For this reason, the submitting agency should always send in suspect and elimination standards to compare to unknown questioned impressions.

Chapter 12

Automated Fingerprint Identification System (AFIS)

The AFIS is a computer-based system for cataloging, searching, matching, and storing known finger and palm prints, latent prints, and related demographic data. It is able to acquire, digitize, process, store, and retrieve known finger and palm print images from arrest and applicant records, and latent finger and palm evidence images. Latent finger and palm prints can be searched against the known standards for potential matches, and saved for searching against all incoming records. As the State's central repository for fingerprint records, the AFIS interfaces with the FBI's Next Generation Identification System (NGI), and gives agencies access to nationwide criminal justice information.

I. Services that the AFIS Unit provides

The AFIS Unit, located at the Wisconsin State Crime Laboratory in Madison, maintains the Wisconsin AFIS system. All fingerprint records submitted to the state come through the AFIS Unit, are checked for quality and possible duplicates, and are stored in the database. If assistance is needed in locating a submitted fingerprint record, contact the AFIS Unit and be ready to provide the following information: Agency name, phone number, point of contact, the subject's name, DOB, and the Transaction Control Number (TCN) of the record being sent to the AFIS. The TCN is issued by the livescan device and can be found by opening the record after capture of the prints. The TCN is the most helpful piece of information a submitter can provide to the AFIS Unit to assist in locating a submission.

Additionally, the AFIS Unit can assist in any non-evidentiary fingerprint comparison an agency may require. These include postmortem identification, unknown identity, questioned identity, and more. When a law enforcement agency needs one of these comparisons, submission of a fingerprint record to the AFIS Unit is a quick way to see if the subject has an existing record within the AFIS or NGI system. Requests will be handled during standard Wisconsin State Crime Laboratory working hours: M-F; 7:45a to 4:30p.

Comparison requests

To submit a comparison request to the AFIS Unit:

- Emails should be sent to dojcrimelabafis@doj.state.wi.us
- Include an agency contact name and phone number for issues and/or results.
- If known, include the subject's full name and date of birth.
- If requesting comparison to a known standard, include the WI SID.
- Fingerprint cards that are emailed for search purposes should:
 - be scanned at a minimum of 600 ppi
 - be submitted as a TIFF, PDF, or JPEG.
- Contact the AFIS Section at the above email if submitting a different file type (due to file size limits on email) or for additional clarification.
- Result may be available the same day as submission.

II. Capturing fingerprints for the AFIS

Finger and palm prints taken at booking facilities throughout the state are typically captured electronically with a livescan device. This creates an ANSI/NIST record, the electronic format used by the state and FBI for processing records in the AFIS.

Any questions concerning recording digital or physical finger or palm prints may be asked of the AFIS Unit at dojcrimelabafis@doj.state.wi.us or at (608) 266-2031. Please have the TCN for the record in question to help us locate it.

Taking Legible Fingerprints and Palm Prints

A good fingerprint/palmprint image is one that provides sufficient data to accurately identify the pattern and the changes on the ridges. When capturing prints, there are two types of impressions. Rolled impressions are the ten individually collected prints in the upper half of the card. They are rolled nail-to-nail (side-to-side) to obtain all available ridge detail. Plain impressions, sometimes known as slaps or flats, are located at the bottom of the fingerprint card and are laid down simultaneously in a single up-and-down motion. Plain impressions are used to verify the sequence and accuracy of the rolled impressions. To capture the best fingerprint/palmprint information for the database:

- Make sure the livescan platen (surface) is clean
 - A buildup of oils, dirt, and old prints on the glass platen and a scratched or damaged platen can cause the captured image to be of poor quality.
 - The printing system should be scratch free, receive regular cleanings, maintenance, calibration, and be checked for compliance with current standards for image compression.
- Center the finger when rolling and roll from nail to nail.
- Leave the livescan image quality and sequential settings turned on.
- Review the images on screen during capture for clarity and orientation of prints. Check to confirm the rolled impression is oriented upright and not tilted.

- When taking palm prints, ensure that gentle pressure is applied on the center of the back of the hand to capture all detail. Otherwise, the image may be missing a large portion of ridge detail.
- When taking writer's palm prints, start with the palm of the hand flat on the platen and then roll up towards the little finger side of the hand about 45 degrees. If no ridge detail is seen, tilt the hand less and re-capture the image.
- Note that the Wisconsin DOJ will only accept an electronic palm print record if it is sent in conjunction with a ten-print record from the same individual.

Image Quality

Obtaining high quality impressions on finger and palm print cards can be best achieved through continued practice combined with the right equipment, its proper installation, and knowledge of how to use it. Each fingerprint and palm print coming into the AFIS is reviewed for quality before being accepted. This check for quality allows the AFIS Unit to provide the best assistance to submitting agencies and build an accurate and effective database. Finger and palm print images of low quality or clarity may be rejected, which would require re-collection to insert the record into the AFIS.

If assistance is needed in locating a submitted fingerprint record, contact the AFIS Unit with the Transaction Control Number (TCN) of the record being sent to the AFIS. The TCN is issued by the livescan device and can be found by opening the record after capture of the prints. The TCN is the most helpful piece of information a submitter can provide to the AFIS Unit to assist in locating a submission.

Chapter 13

Burglary

Burglary is one of the offenses most commonly encountered by law enforcement officers. The initial investigation of a burglary scene is extremely important, for the objective is not only to determine what may be missing, but also to locate and recover physical evidence which associates the burglar with the crime scene. The following outline may be used by the investigating officer as a procedural guide when processing a burglary scene.

Caution: Observe laws relating to the collection of evidence.

I. Evidentiary Considerations

- A. Security and Protection at the Scene
 1. Allow authorized personnel only.
 2. Rope off or barricade area under investigation.
 3. Protect outside areas from elements with a new tarpaulin or plastic sheet.
 4. Maintain security until the scene is completely processed.

- B. What to Look for
 1. In surrounding area:
 - a. Footwear impressions (determine origin)
 - b. Tire marks (determine origin)
 - c. Drag marks
 - d. Abandoned loot, tools, clothing, etc.
 2. At scene:
 - a. Point and method of entry
 - b. Object of burglary
 - c. Point and method of exit
 - d. Obvious objects of value "passed up"

- e. Fingerprints, glove imprints
 - 3. At point of entry:
 - a. Hairs, fibers, other materials
 - b. Chips of paint, wood, glass, and tools
 - c. Blood
 - d. Tool marks (photo)
 - e. Tools
 - f. Other items of evidence
 - 4. Inside burglarized premises:
 - a. Finger, foot, footwear, and palm prints
 - b. Burglarized objects
 - c. Tools and source of tools (property of victim or perpetrator)
 - d. Tool marks (photograph)
 - e. Broken or fractured pieces of tools (may be recovered in floor sweepings)
 - 5. Suspect:
 - a. Trace materials may be present on the clothing of a suspect. Therefore, all outer clothing should be submitted to the Trace Evidence Unit according to procedures outlined in Chapter 19, Clothing and Fabrics.
 - b. The vehicle involved should be thoroughly searched for the presence of physical evidence. Vacuum seats, floors, dash separately.
- C. Procedure at Scene
- 1. Photograph and diagram the crime scene.
 - 2. Recover, mark and preserve physical evidence found according to directions set forth in section pertaining to evidence of that type.
- D. Materials Required by the Laboratory
- 1. Physical evidence that has been photographed, recovered, marked and preserved in the proper manner.

II. Safe Burglary

In some rare cases, a safe may be drilled with a core drill to gain entrance. In these sophisticated types of burglary, the Laboratory should be contacted for assistance. A diagram describing the accepted nomenclature of parts usually encountered in a safe burglary investigation has been included in an effort to show the correct names of safe parts. Knowledge and use of this terminology will aid the investigator and the Forensic Scientist in communicating effectively regarding safe burglaries.

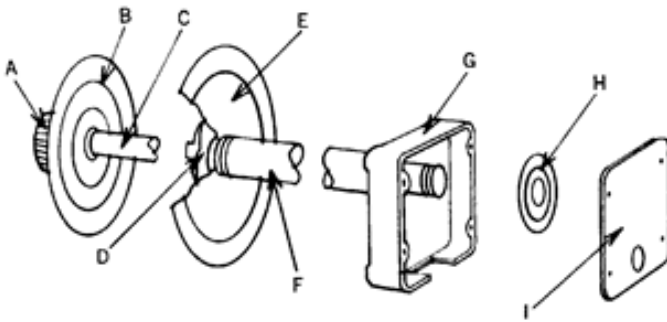

Fig. 13-1 Combination lock nomenclature A) Dial Knob, B) Dial, C) Spindle, D) Tube Nut, E) Dial Ring, H) Wheel Spindle.

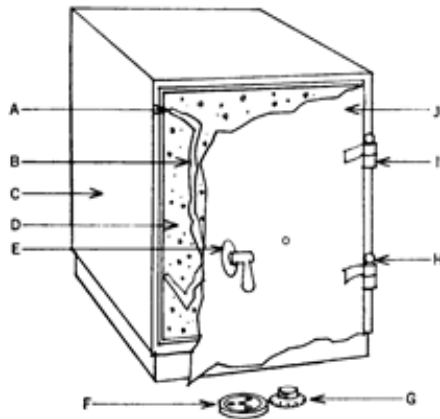

Fig. 13-2 A) Locking Bolt, B) Carrying Bar, C) Cladding(outer metal shell), D) Firewall Material, E) Door Handle, F) Dial Ring, G) Dial, H) Hinge Accord, I) Hinge, J) Front Plate.

Although explosives are not employed very often in safe burglaries, the possibility of their use should not be overlooked. If there is reason to suspect explosives were used, it is recommended the scene be evacuated and secured. Then, for guidance in handling the situation, contact one of the following:

- A local bomb squad
- The Federal Bureau of Alcohol, Tobacco and Firearms (ATF) - in Wisconsin, (414) 297 - 3100

If explosives are expected:

Do not attempt to neutralize or destroy remaining explosives.

Do not turn on any electrical switches.

Do not walk or step in a liquid or suspected explosive material.

Do not move any object.

Do not smoke or use matches in area.

Do not pick up any detonators or explosives.

Do not breathe any vapors which may be present.
Nitroglycerine may cause a very severe headache.

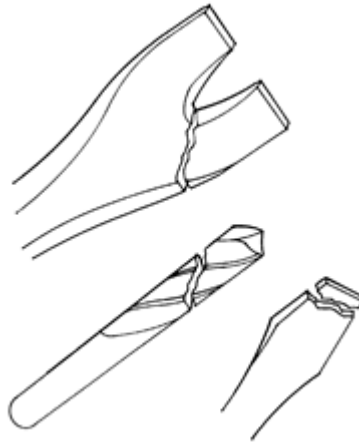

Fig. 13-3 Fracture Matches – broken tools.

After the scene has been processed for finger-, foot-, and palm prints, it should be carefully swept to recover all debris. The debris pile should be thoroughly searched for the presence of broken tool parts and other physical evidence. Broken tool parts may be fracture matched with a suspect tool. This is a conclusive type of identification and is not uncommon in burglary investigations. The recovery and search for debris is frequently overlooked, however, resulting in the loss of valuable evidence.

Chapter 14

Building Materials

In investigations which involve breaking and entering, building materials such as paint, glass, wood, plaster, metal, etc., may adhere to the perpetrator's clothing or tools. These fragments may later be identified as originating from the scene. Building materials from different sources -which appear by visual examination to be similar - may be differentiated by their physical and chemical properties.

Procedure

A. Crime scene:

1. At the point of entry, or at any point of damage, collect samples of each type of building material involved (*Fig. 14-3*). Do not cut through tool marks. If one type of material has been damaged in several places, obtain known samples from each site since the composition may vary.
2. Any tool or instrument impressions found on building materials should be properly preserved and submitted to the Laboratory. Recover known sample of building materials from point of entry (*see Fig. 14-3*). Foreign paint in the impression may be linked to paint on a suspect tool. Use caution to preserve foreign matter.
3. When glass has been broken, collect all glass found at the scene. If more than one window has been broken, glass from each pane should be packaged and submitted **separately**. This also applies to thermo- or double pane windows and laminated windows. Do not collect glass from the

ground if it can be collected directly from the source (i.e., window).

If the direction of force used to break a window is in question, collect all glass from the window frame and from the ground inside and out. If the glass is removed from the frame, be sure to mark one surface to indicate whether it was "inside" or "outside" when in the frame. Package each sample separately or submit the window frame with the glass in place (see *Chapter 15 - Glass*).

4. Care should be taken in choosing a container to avoid loss or contamination of the evidence. Double packaging is preferred, especially if pieces of glass are small as they can easily be lost. This can be achieved by placing glass in envelopes or paper folds and then into a pillbox or rigid container.
5. Containers should be marked with the following information, sealed, then submitted to the Laboratory:
 - a. Description of contents including whether the sample is a questioned or known sample
 - b. Exact source of contents
 - c. Date and time recovered
 - d. Case and item number
 - e. Name of officer recovering the material
6. Recover all tools remaining at the scene for possible fingerprints and/or DNA.

B. Suspects:

1. Collect all clothing worn by the suspect at the time of crime, including shoes (see *Chapter 19 -*

Clothing and Fibers). Shoes should be packaged separately from clothing.

2. Examine head and all bare skin areas (hands, arms, legs, feet) for fresh cuts that might contain building materials, especially glass. Building materials trapped in hair can be recovered by combing over a clean piece of paper or cloth sheet. Collect all trace evidence and combings.
3. Collect all suspect tools.
4. Examine interior and trunk of suspect's car for debris and traces of building materials.
5. If the suspect claims a source for materials found, obtain a known sample from the claimed source.
6. Package all of these samples separately as described above. Avoid cross-contaminating samples taken from the suspect with those taken from the scene.



Fig. 14-1 Trace transfer of materials may be found adhering to pry bars.



Fig. 14-2 Glass chips recovered from the suspects clothes which are consistent with glass broken at the scene.

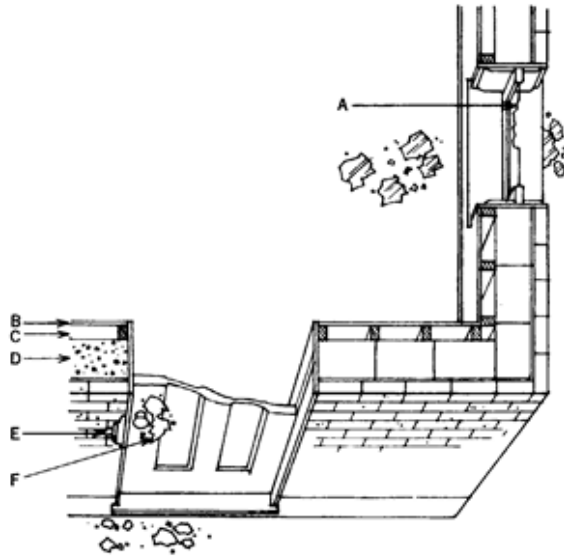

Fig. 14-3 This cross section of a burglary scene shows the various materials that should be recovered. In this case, an unsuccessful attempt was made to gain entry by forcing the door frame and adjoining wall. Entry was finally gained through the window.

Known samples should be taken of all damaged materials: A) Known glass remaining in the window frame, B) Wallboard, plaster, wallpaper, paint, etc., C) Building insulation, D) Building block and mortar, E) Brick and mortar, F) Wood from door.

Chapter 15

Glass

One of the more important types of physical evidence which is frequently overlooked by the investigator is glass. Its evidentiary value lies in the fact that there are thousands of different formulas used in the manufacturing of glass.

I. General

Glass that is most often encountered in forensic casework falls into the category of window/windshield glass.

An example of this is:

The glass recovered from a broken window at a burglary scene and glass recovered from the clothing and shoes removed from a person suspected of committing the burglary.

It should be noted that the glass which is recovered from a known source, such as a broken window or a door, is considered **known** glass. The glass recovered from the clothing and shoes, or the hit-and-run scene is considered **questioned** glass.

Comparison of irregularly shaped fractured edges of pieces of glass may reveal a puzzle-like match which indicates that two sources of glass were at one time a part of the same object. It should be noted that tempered float glass, the kind used in vehicles, business windows and doors, and residential shower doors **cannot** be fracture matched as they expand upon breaking.

If a fracture match is not possible, comparison of known glass with questioned glass may reveal

similarities in their physical, optical, or chemical properties. This type of examination may result in a class identification. That is, there is more than one headlight or window that will have the same properties as the known window. Therefore, specific identification cannot result from measurements of physical, optical, or chemical properties.

It is also possible to determine the direction of force used to break glass by examining stress marks present on the broken edges. In order to do this, it is necessary to reconstruct as much of the original pane as possible. Therefore, **all** glass from the scene must be recovered to reconstruct the item so the point of impact can be determined, and detailed examination of the individual fragments can be conducted.

Caution: Observe laws relating to the collection of evidence.

II. Procedure

A. Fracture matches

1. Fracture matching is the most positive form of identification and therefore it is of utmost importance that all glass fragments be recovered, since it is impossible to know in advance which recovered pieces will mate with one another.
2. Collect **all** glass fragments from **all** sources (i.e., scene, vehicles, clothing, etc.) and package glass from each source **separately** in order to associate the glass from any one source with the scene.

B. Chemical analysis

1. Collected for comparison with glass samples recovered from remote locations or from the

clothing to show commonality of chemical make-up. (Does *not* individualize a sample to a single source.)

2. Recover a sample of glass still in the frame. Glass from the window frame is the only source that can be used as a known for chemical analysis.

C. Determination of the direction of force

1. It is preferable to remove the window frame with the remaining glass still in place and to submit it to the Laboratory. If this is impossible and the glass must be removed from the frame, be sure to mark each piece to indicate the "inside" surface or the "outside" surface before removed from the frame. Collect all glass from the window frame.
2. Glass found in different areas should be recovered and packaged separately. Example: Glass found on the floor inside should be packaged separately from glass found outside. It cannot be overemphasized that glass recovered from different areas should be packaged separately.

D. Packaging

1. Glass should be double packaged to prevent loss, particularly if the pieces are small fragments or shards. Place pieces in an envelope or paper fold and then into a pillbox or rigid container. Protect the broken or fractured edges of the pieces of glass from any additional damage or breakage.
2. The value of the procedure for packaging glass from different sources separately will be nullified if the packaging material tears or breaks, allowing transfer of small pieces or fragments of glass between packages.

Chapter 16

Tool Marks

Tool mark identification techniques may be applied to many types of evidence in investigations (e.g., knife marks on bone, fractured knife blades, vise marks on homemade explosive devices, crimp marks on detonators, cut marks on wire, fractured radio antennas, etc.) including burglaries.

I. General

For the purposes of this chapter, a tool is any instrument or object capable of making a mark on another object.

A close examination of a tool mark may reveal the type of tool, contour of the cutting or prying edge, prying edge width or the presence of trace material

II. Types of Tool Marks

Generally, tool marks encountered at a crime scene may be in the form of impressed markings, striated "drag" or "shear" marks created by tool movement during contact, or a combination of both (see Figures 16-1 and 16-2). For example, a drive punch will generally leave an impression tool mark, whereas a screwdriver or pry bar will frequently leave a striated mark as well as an impression of the tip of the tool.

III. Location of Tool Marks

Tool marks may be found at entry and exit points in buildings or vehicles and upon objects which have been attacked with a tool or other object.

IV. Recovery of Tool Marks

- A. Always submit the object exhibiting tool mark(s) to the Laboratory.
- B. If it is not practical to submit the object, remove the section of the material containing the tool mark and submit the section to the Laboratory.
- C. Only as a last resort, make a cast of the tool mark.
- D. Mark, protect and individually package item(s) containing tool mark(s) and submit to the Laboratory.

V. Casting of Tool Marks

Silicone based casting materials have been found to be satisfactory for casting tool marks although not all materials perform adequately. Brown "Mikrosil" possesses the best combination of casting and examination qualities. Directions for their use are contained in each kit.

Do not use Plasticine®, plaster of Paris, patch plaster and similar materials which have a tendency to shrink.

VI. Tools Caution: Observe laws relating to the collection of evidence

Recover and inventory all suspect tools observing the following precautions and submit them to the Laboratory for examination and comparison with tool marks.

- A. Never place a suspect tool in contact with a questioned tool mark or cast.
- B. Inscribe identification marks on tools for later identification. Exercise extreme care in handling and marking tool(s) if it is to be checked for fingerprints, DNA and/or trace evidence.

- C. Package each tool individually to prevent cross-contamination.

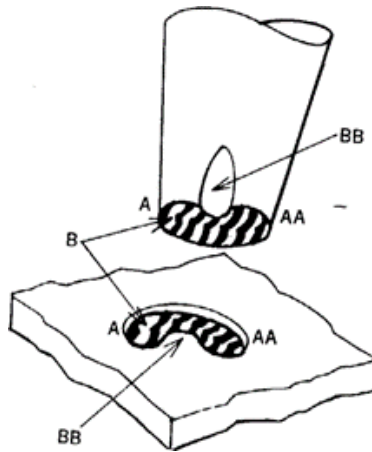

Fig. 16-1 Impressed Tool Mark

- A-AA portion of the tool mark reveals the class characteristics (size and shape) of the tool.
- B-BB reveals individual characteristics of this particular tool. Marks on surface B are grinding or manufacturer's marks; BB is a nick in the edge of the tool.

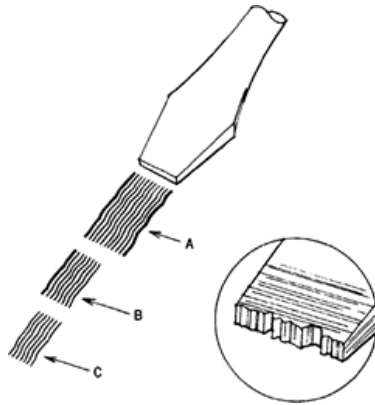

Fig. 16-2 Striated tool mark

- Area A shows the entire prying edge width of the tool. The intervening lines, or striations, are the unique marks created by the tool's individual physical characteristics.
- Area B, a partial tool mark, shows one side of the prying edge of the screwdriver and unique marking detail.
- Area C, a partial tool mark, does not show either side of the prying edge, but does show individual markings.
- Inset circle shows an enlarged view of the edge of the tool's prying edge, showing individual physical characteristics acquired during manufacture, use, misuse, regrinding, or intentional alteration.



Fig. 16-3 Double-bladed tools such as bolt cutters are often used to cut padlock shackles. When recovered in the possession of a suspect, they may connect the offender with the crime.



Fig. 16-4 Damage to the cutting edges of the blades creates individual markings on the materials cut by the bolt cutters.

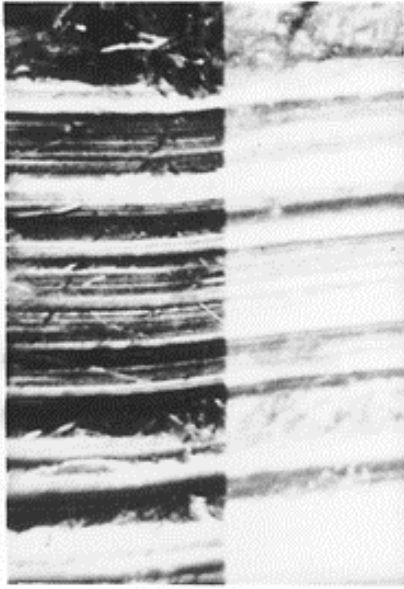

Fig. 16-5 This comparison microphotograph illustrates matching patterns of unique detail that result in an identification in a tool mark comparison.

Chapter 17

Paints

Paint chips and fragments of other protective coatings such as varnishes, sealers, lacquers, enamels, and plastics are frequently recovered at scenes of burglaries, hit and run vehicles and scenes, forced entries, etc. A determination of common origin is possible in cases where irregularly shaped adjoining edges of paint chips can be physically joined to form a fracture match (see Figure 17-1). However, the value of a single-layered paint chip or paint smear should not be overlooked.

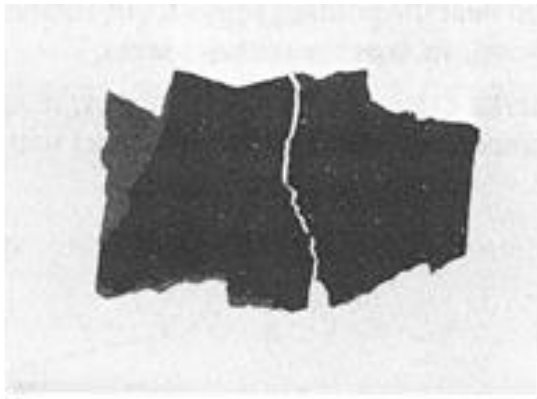

Fig. 17-1 Fracture match of paint chips. Two fragments of paint showing a common fracture match. One fragment was found at the scene of a crime. The other was recovered from the suspect vehicle.



Fig. 17-2 Cross section of multi-layer paint chip. Each layer represents a separate painting operation (Magnification approximately X350).

Procedure

The following procedures are recommended for recovery of paint samples.

Caution: Observe laws relating to the collection of evidence.

1. Recover, package, and seal all paint samples separately.
2. Recover known paint samples from areas immediately adjacent to the damaged area. The hoods, trunks, and fenders of vehicles may have different paint systems used by the manufacturer or have been repainted at some point. Therefore, it is of utmost importance that a known paint sample be taken from the exact part of the vehicle upon which the damage occurred. In hit-and-run investigations, the known paint samples should be taken near the point of impact, but should not be taken from areas of corrosion, such as the rocker panels.
3. When tool marks exist on a damaged object, recover paint samples from areas immediately adjacent to tool marks without mutilating the tool mark.



Fig. 17-3 Recovery of Paint Sample: Tape a clean sheet of paper (do not use envelopes) to the object in the manner shown, forming a pocket. Mark the paper for identification. Scrape the questioned paint into the pocket formed by the paper. It is important to use a new, disposable scalpel blade or razor blade for each sample to avoid contamination. Some razor blades are coated with oil to prevent rusting. Therefore, all razor blades should be thoroughly cleaned with a clean cloth or tissue just before they are used.

4. When areas of paint are missing from sheet metal parts of vehicles or doors and windows of residences and businesses, consideration should be given to bringing the entire part to the Laboratory for possible fracture match analysis.
5. Double packaging is preferred, especially if pieces of paint are small as they can easily be lost. This can be achieved by placing paint chips in envelopes or paper folds and then into a secondary envelope or container. Seal and mark appropriately.

6. Use a new, clean scalpel blade or razor blade for each sample recovered. Seal and mark appropriately.
 - a. **Safety tip:** when using a single-edged razor blade, a commercially available razor blade holder should be used to avoid injury if the blade slips or breaks during sampling.
7. A clean, sharpened putty knife or slot-head screwdriver can be used at times to start collecting harder paint samples. A separate pre-cleaned putty knife or screwdriver should be used for each known and questioned paint.
8. **DO NOT USE tape lifts or other gummed tapes to recover paint samples.** It interferes with the chemical analysis.



Fig. 17-4 Packaging Paint Sample: Carefully remove the paper from the object and fold each edge toward the center so that the packet is completely closed.

Chapter 18

Metals

It is possible to compare metals on the basis of their elemental composition and surface morphology. Even minute particles can be examined. Questioned metal fragments which have been broken from their original source may often be fracture matched to that source.

Caution: Observe laws relating to the collection of evidence.

Procedure

1. Recover all metal fragments found at the scene. These should be sealed in vials, bottles, paper bags or other suitable containers. Package and label.
2. Recover and submit all metal objects involved or encountered in an investigation. Although metal fragments may not be found at the scene, they may be detected later when the clothing is examined, since they may adhere to the surface or lodge in pockets and cuffs or to shoes. Therefore, it is important to have for comparison the object from which the fragments may have originated.

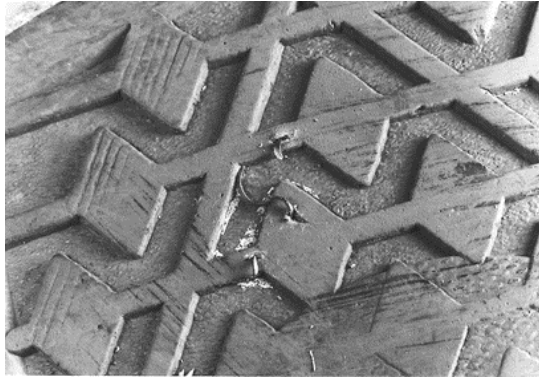

Fig. 18-1 Trace metal and glass fragments can often be recovered from the soles of shoes if the suspect walks through such evidence during commission of the offense.

Chapter 19

Clothing and Fibers

Clothing fibers or small pieces of fabric found at burglary scenes, on suspect hit-and-run vehicles, weapons, or other objects can often be compared or even matched with a suspect's or victim's clothing. Small particles of paint, plastic, metal, wood, glass, soil, or other materials frequently adhere to clothing (pockets, trousers, cuffs, etc.) and may be related to the scene.

The Laboratory has special equipment to recover trace evidence from clothing. Clothing recovered for examination should be handled with care to avoid damage to critical areas. It is important to collect clothing before it is cleaned or otherwise altered. Trace materials are usually removed or lost in the cleaning process.

Caution: Observe laws relating to the collection of evidence.

I. General Procedure

- A. Recover clothing to be examined. Clothing should be carefully removed from the person or body. Care should be taken to minimize damage to garments. **Do not** cut through stains, bullet holes, or knife penetrations. Collect and package each item separately. It is extremely important to keep items separated to avoid contamination during recovery, storage, and transmittal to the Laboratory.
- B. Clothing or other items that are damp or wet with blood, urine, water, etc., should be air dried in a draft-free place prior to packaging. **Do not package damp clothing or other damp items**

in plastic bags. A piece of clean paper should be spread under drying items to catch any debris which might be dislodged. The paper and any debris thereon should be packaged with the item. Label, seal and submit to the Laboratory.

EXCEPTION: Clothing which needs ignitable liquid analysis should be packaged to preserve volatiles. See Chapter 25 - Arson.

- C. Package each dry item in a clean paper bag, label, and seal.
- D. Plastic bags are **not** suitable at any time for packaging shoes and other leather objects. A new, clean paper bag should be used for each leather object.

II. Packaging Items

- A. Mark the paper bag with identifying data (description, source, date, time of recovery, case number, initials of persons involved in recovery, and other pertinent information).
- B. Seal the bag using one of the methods discussed in Chapter 1 - Evidence Integrity.



Fig. 19-1 Fabric impression on a license plate from a hit-and-run investigation.

Chapter 20

Hairs and Fibers

In crimes where personal contact has occurred, especially if there was physical force, hair and fibers are frequently found as evidence. A cross transfer of hair and/or fibers between a victim and an assailant can provide supportive evidence of an association. In addition, hair recovered from the scene may serve to associate an individual with the scene. Fibers recovered from the clothing of the victim, suspect and crime scene can be compared to known textile materials to determine possible sources of origin.

If a hair is determined to be of human origin and is deemed probative to a case, DNA analyses may be performed on the root (if present) of the hair. Another form of DNA analysis (mitochondrial analysis) may be performed on the hair shaft if the root is absent.

NOTE: Mitochondrial DNA analysis is not available at the WI State Crime Laboratories. See Chapter 7 - DNA Evidence and Standards for more details.

I. Collection of Hair and Fiber Standards

It is necessary to obtain standard hair and fiber samples from all possible sources (suspect, victim and scene) for comparison with questioned hairs and fibers.

DNA analysis on hair roots has replaced microscopic hair comparisons. Pubic and head hair standards are still necessary for determining which foreign, questioned hairs may be subjected to DNA analysis. Due to the ease of head hair transfer and potential limited probative value, DNA analysis on hairs will be limited.

- A. *Head hair standards.* Obtain at least fifty (50) head hairs by cutting them at the skin surface. These hairs should be collected from various areas of the head such as the crown, sides, front and back to assure that all shades of color and texture have been adequately sampled. The quantity of hairs obtained from a deceased individual should be doubled and the hairs should be **pulled**. Place the hairs in a clean, properly labeled envelope and seal.
- B. *Pubic hair standards.* Obtain at least twenty (20) pubic hairs by cutting them at the skin surface. The hairs should be collected from various areas within the pubic region. If this is a deceased individual, double the number of hairs to be collected and pull them. Place the hairs in a clean, properly labeled envelope and seal.
- C. **Known fibers** should be obtained from all possible sources (clothing, drapes, rugs, etc.).
1. Submit the suspected source in total if possible. Place the source in a clean, properly labeled paper bag and seal. (*See Chapter 19 - Clothing and Fibers.*)
 2. If it is not feasible to submit the source in total, a sufficient quantity should be taken to ensure that each color and kind of fiber involved has been sampled. A swatch of fabric or several yarns from the item is preferable to individual fibers. Place the fibers in a clean, properly labeled envelope or glass jar and seal. (*See Chapter 19 - Clothing and Fibers.*)

II. Collection of Questioned Hair and Fibers

- A. *Pubic hair combings.* (Usually collected in sexual assault cases and from homicide victims).

Place a piece of paper under the pubic region of the individual and comb through the entire pubic area to dislodge any foreign hairs or other material that may be present. Place the used comb onto the paper and fold the paper around the comb being careful not to lose any of the dislodged evidence. Place the wrapped comb in a clean, properly labeled envelope and seal.

- B. *Other Recovered Questioned Hairs and Fibers.*
Separately package the hairs and fibers collected from different persons and different locations/sources.

1. When the amount of evidence is very small, extreme care should be exercised to avoid contaminating or inadvertently losing the material. Double packaging is recommended.
2. The hair or fiber(s) should be placed on a piece of clean white paper and the paper should be tightly folded around the hair or fiber. Place the paper packet in a clean, properly labeled envelope and seal.

Chapter 21

Fracture and Tear Matches

If the irregularly shaped fractured or torn edges of two or more pieces of any material can be joined together to form a continuous section, then it can be concluded that the pieces at one time shared a common origin. This comparison is the most positive conclusion that can be drawn in the area of trace evidence. The Forensic Scientist has eliminated all other similar materials as the source of the pieces.

Investigators often carefully check a scene for fingerprints or DNA, knowing their value to conclusively link a person to the scene – while overlooking a torn piece of paper, a broken piece of metal or glass, or another broken item. Any of those items can, if another piece is found in the possession of a suspect, form just as conclusive a link with the scene.

A fracture match results when two pieces of rigid material (plastic, wood, glass, metal, etc.) from separate locations are reconstructed to form a continuous section of that material (see Table 21-1). A cut or tear match results when two pieces of pliable material (such as, plastic bags, paper, foil, fabric, etc.) from separate locations are reconstructed to form a continuous section of that material. Perforated paper products (checks, notebook paper, LSD blotter paper, etc.) can often be linked back to their source via tear matches (see Table 21-2).

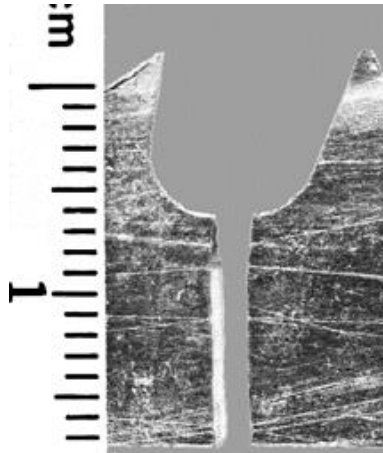

Fig. 21-1 Fracture match of a broken saw blade.

Table 21-1: Examples of Potential Sources for Fracture Matches

Motor Vehicles	Bicycles	Burglary	Miscellaneous
Paint chips	Tubular metal	Paint*	Knives
Headlights	Reflectors	Wood*	Feathers
Grill	Lights	Tool parts	Stone
Exterior mirrors	Tires	Glass	Bones: Animal Human Fingernails
Antenna	Inner tubes	Safe wall	
Windshields	Spokes	Metal	
Wipers	Fenders	Doors	
Parking lights	Baskets	Trim	
Taillights		Machinery	
Trim pieces			

*Fractured material may be found adhering to a tool.

Table 21-2: Examples of Potential Sources for Tear/Perforation Matches

Matches	Cardboard
Documents	Money
Paper bags	LSD blotter paper
Checks	Drug folds
Stamps	Cloth/fabric
Sheet plastic	Plastic bags
Duct tape	Other Tape

Importance of Thorough Collection and Proper Preservation

It is of the utmost importance that all pieces of the broken item(s) at the scene be collected and preserved for later comparison with similar evidence collected from the suspect, victim, vehicle, home or other scenes; it is impossible to know in advance which pieces will be matched to each other. This requires a careful and thorough search of the scene.

Package items from each location separately. In order to confidently establish a link between an item left at the scene and another item recovered elsewhere, each item's origin must be documented. If items are, or could be co-mingled during collection, storage or transport, their evidentiary value is lost. *See Chapter 1 - Evidence Integrity for further information on packaging and sealing.*

For information on specific types of fracture matches and procedures associated with their collection, see the following chapters: Chapter 13 – Burglary, Chapter 14 - Building Materials, Chapter 15 – Glass, Chapter 16 - Tool Marks, Chapter 17 - Paints, Chapter 18 – Metals, Chapter 22 - Vehicles.

Chapter 22

Vehicles

The Laboratory accepts cases involving automobile accidents which have resulted in injury or death and where criminal negligence is suspected. Vehicles involved in accidents of this type should be immediately impounded. Where skid damage on the vehicle's tires may indicate related important conditions prior to or at the time of impact, the vehicle should be conveyed on a trailer to a storage facility. The Laboratory also may accept vehicles involved in the commission of a sexual assault or conveyance of a body. Always contact your area laboratory prior to submitting the vehicle.

It is very important that proper photographs of the scene, skid marks, damage to vehicles, impact damage, etc. are obtained. The Laboratory does not perform accident reconstruction, or condition of mechanical or electrical systems determinations. These types of analyses must be sought from another source.

Criminal Damage to Motor Vehicles and Engines

The perpetrators of criminal damage to motor vehicles may add a foreign substance, such as emery dust or sand, to the vehicle engine or transmission. Where internal damage of this type is suspected, a sample, consisting of one pint of oil from the top and bottom of the oil pan of the damaged engine, should be submitted. Any foreign residue found on top of the engine in the carburetor, or near the oil spout should also be submitted. It is important that as much sediment as possible be obtained from the oil pan or gear box.

In cases involving addition of sugar or other materials to gasoline, submit **at least** one pint of gasoline from

the tank. Because sugar has a low solubility in gasoline, it is imperative that the intact fuel filter as well as a sample of the sediment or condensation (water) in the bottom of the gasoline tank be submitted.

Samples from fuel pump bowls should be avoided because they contain sediments which interfere with tests. However, the sediment bowl can be removed so that a sample of gasoline may be pumped directly into the sample container.

Containers with rubber or waxed paper seals should not be used, since they dissolve in petroleum products and give erroneous test results. Pistons, bearings, gears and scrapings from the combustion chamber or rings may also be submitted. Samples of the radiator coolant also may be examined for evidence of foreign substances when indicated.

Caution: It is unlawful to send flammable liquids via mail

Stolen Vehicles

The Laboratory may be able to identify stolen vehicles which have been repainted or stripped or which have had the serial or manufacturing numbers altered or replaced.

If a vehicle is suspected of having been repainted, it is possible to analyze and photograph the paint layers as confirmatory evidence and to establish the original factory color. *See Chapter 17 - Paints for the recovery technique.*

When an automobile has been stripped and the suspect parts are found, the Laboratory may be able to physically match these to the vehicle.

Stamped serial numbers may be removed by grinding or altered by other methods. Frequently, they may be restored. When alteration of the serial number is suspected, the object or part bearing the serial number should be submitted.

For general technical information, contact the Laboratory or the National Insurance Crime Bureau (NICB) at www.NICB.org. In some cases, confidential, hidden vehicle identification numbers may be present to assist in determining authentic vehicle identification.

Hit-and-Run Investigations

In attempting accident reconstruction, the investigator should be mindful that showing a relationship between materials or items recovered from different locations is most important. Materials or items recovered from different sources or at a later date that can be related to each other constitutes very important evidence. Three primary sources should be considered: the accident scene, vehicles and victims.

I. Accident Scene

- A. Initial Procedures:
 - a. Request ambulance personnel at scene to preserve blankets and clothing which may contain trace evidence such as broken glass, paint chips, metal parts, plastic, etc.
 - b. In vehicular accidents, an officer should be assigned to the hospital to assist in the recovery of clothing and body fluids.
- B. Protect scene from:
 - a. Additional accident damage
 - b. Bystanders
 - c. Theft from vehicles
- C. Establish a written record:
 - a. Date
 - b. Time

- c. Location
 - d. Description of incident
 - e. Weather conditions
 - f. Temperature
 - g. Road conditions
 - h. Victim's location upon your arrival, his/her condition and tentative identification
 - i. If a description of the hit-and-run vehicle can be obtained, immediately have dispatcher alert other officers in the surrounding area. The vehicle's description may be obtained from eyewitnesses or materials recovered at the scene.
- D. Attempt to locate the fleeing driver and/or vehicle
- E. Photograph the scene (*see Chapter 3 - Forensic Photography*).
- F. Diagram the scene (*see Chapter 5 - Crime Scene Sketch*).
- G. Recognition of potentially valuable materials:
- a. Broken glass (headlights, mirrors, and windshield) or plastic from scene or from victim's clothing may be fracture matched with remaining glass or plastic from suspect vehicle.
 - b. Broken or fractured pieces of metal (trim, antenna, or sheet metal pieces) may also be fracture matched with section remaining on vehicle.
 - c. Paint chips from scene or vehicle may be fracture matched with suspect vehicle (*see Fig. 22-1*). Paint layer relationship may be valuable evidence (*see Figs. 17-1 and 17-2 in Chapter 17: Paints*)
 - d. Dirt deposits recovered from road surface may be indicative of approximate point of impact.
 - e. Physical impressions left on objects at the scene may indicate the make of vehicle causing the impact. They should be

properly recorded and collected for possible comparison purposes at a later date.

- f. Skid marks and three-dimensional and surface impressions sometimes can be used to determine direction and speed. There are limitations to the usefulness of skid marks, debris, and gouge marks in establishing the exact point of impact. They will, however, indicate the approximate location of the collision. Broken parts found at the accident scene may bounce and roll; therefore, reliable information as to exact point of impact may not be able to be determined.

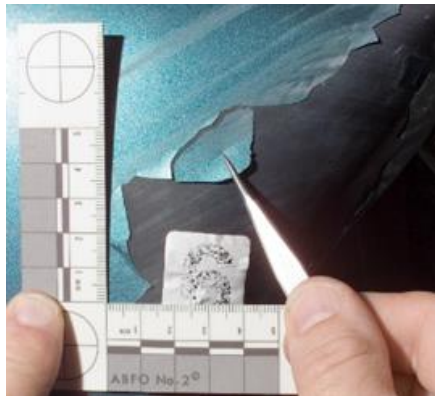

Fig. 22-1 Paint chip fracture match to a suspect vehicle believed to be involved in a fatal hit-and-run accident.

II. Victim

1. Living

- A. Obtain complete identifying data to include full name, date and place of birth, permanent address, temporary address (if nonresident), telephone number where he/she can be reached when discharged from hospital.

- B. Recover blankets used in conveying victim to hospital. Tag blankets and place each in a separate paper bag. Air dry if wet or blood stained. Avoid handling blankets any more than necessary to preclude loss of trace material.
- C. Recover clothing worn by victim at time of accident. Note any cutting or tearing of clothing by nurse, attending physician or other person rendering aid. Tag each item of clothing and place in a separate clean paper bag. Air dry if wet or blood stained. Avoid unnecessary handling of clothing to prevent loss of trace material.
- D. Collect body fluids:
 - a. Blood:
 - i. Collect at least 5 milliliters of blood in a lavender topped (EDTA) blood collection tube, then print patient's name on the label. Using a small syringe, insert needle through the rubber stopper of the tube (EDTA) and withdraw approximately 1 milliliter of blood. Using a DNA Stain Collection Card, fill all four (4) of the printed circles on the card with blood. Allow bloodstains to thoroughly air dry, then write patient's name on the DNA Stain Collection Card. Package the Stain Collection card in a clean, properly labeled paper envelope and seal. Package the blood tube in a Styrofoam shipping container, label properly and seal. Store in refrigerator.
 - ii. Collect 20 milliliters (two tubes) of blood in gray-topped (sodium fluoride) blood collection tubes for toxicological analysis. Print the patient's name on the labels.

Package the blood tubes in a Styrofoam shipping container, label properly and seal (see *Chapter 23 - Toxicology*).

b. Urine:

- i. Collect all available urine in a plastic or glass jar used by hospitals for sample collection. Preservatives are not necessary. Seal and label for identification. Store in refrigerator (see *Chapter 23 - Toxicology*).

- E. Ensure that chain of custody is maintained. Everyone who has the item in his/her custody, even for a short time, must be documented. See *Chapter 1 - Evidence Integrity* for further discussion of this topic.

2. Deceased

- A. Photograph the body (see *Chapter 3 - Forensic Photography*).
- B. Note position of body. If postmortem lividity has developed, determine if it is consistent with position of body when found.
- C. Use caution when removing body to avoid loss of possible trace material. The body should be placed in a new, unused white sheet before being placed in a clean, sealed body bag.
- D. Check under victim for trace evidence.
- E. See Chapter 23 - Toxicology.

III. Vehicle

- A. Avoid touching any part of the vehicle which may bear fingerprints (e.g., steering wheel, mirrors, door handles, brake handle, gear shift handle, seat belt fasteners, hood, windshield, roof, etc.). To shift gears for towing, grasp the stick rather than the end knob where suspect may have left prints.

- B. Protect the vehicle from contamination by covering with new wrapping paper or plastic sheeting.
- C. Transport on a flatbed truck or trailer or tow (do not drive) vehicle to nearest garage. Proper examination of the under-structure requires the use of a hoist.
 - a. The vehicle should not be towed any extended distance. Trace evidence such as blood or hair may be lost or destroyed.
 - b. The vehicle should be towed or hauled from the undamaged end to avoid additional damage and to avoid destruction or addition of evidence during towing (*See Figure 22-2*).
 - c. The vehicle should be placed under lock and key. Police security should be maintained to ensure the custodial chain of the vehicle.



Fig. 22-2 Vehicle towed from undamaged end to an area laboratory.

- D. Photograph the vehicle (*see Chapter 3 - Forensic Photography*).
- E. Record an accurate description of the vehicle.
- F. Recover known and questioned paint samples. Paint samples should be taken from both the damaged areas and adjacent undamaged areas.

The latter serve as controls or knowns during Laboratory comparisons. Paint samples should also be taken from the victim's vehicle. Fenders, hoods and doors with areas of missing paint should be removed for fracture match analysis with recovered paint samples. Where bicycles, baby strollers, snowmobiles, power lawn mowers or other small vehicles are struck, the entire object should be sent to the Laboratory. See Chapter 17 - Paints for procedure in recovering paint samples.

- G. In the event that glass has been broken, recover and submit all known and questioned samples.
- H. Metal, glass and plastic pieces showing fractured edges should be removed, because they may be fracture matched to pieces from the scene.
- I. A systematic examination should be made of the vehicle exterior including the undercarriage.
- J. If the suspect vehicle is located sometime after the accident (after having secured the properly executed search warrant), immediately record the temperature of the radiator and out-of-doors temperature. Record serial numbers, vehicle identification numbers (VIN), license numbers, condition of brakes, tires (evidence of skidding), mileage reading, service record, approximate amount of fuel in tank and condition of all lights.
- K. Examine vehicle for presence of blood, hair and fibers. If investigation indicates vehicle passed over victim, the understructure should be examined. Known samples of grease should be recovered, and recovery location noted.
- L. Fabric weave impressions on metal surfaces or paint and in grease should not be overlooked. When possible, the bumpers, hoods or the entire vehicle should be conveyed to the Laboratory for proper photographic documentation of such impressions. To be of use for comparison, all photos must be life-size (1:1) and include a scale.

- M. Sketch vehicle and note on sketch any damage and the locations of materials recovered. This will be useful during your recollection at any court proceedings (see Fig. 22-3).
- N. Properly mark vehicle for identification.

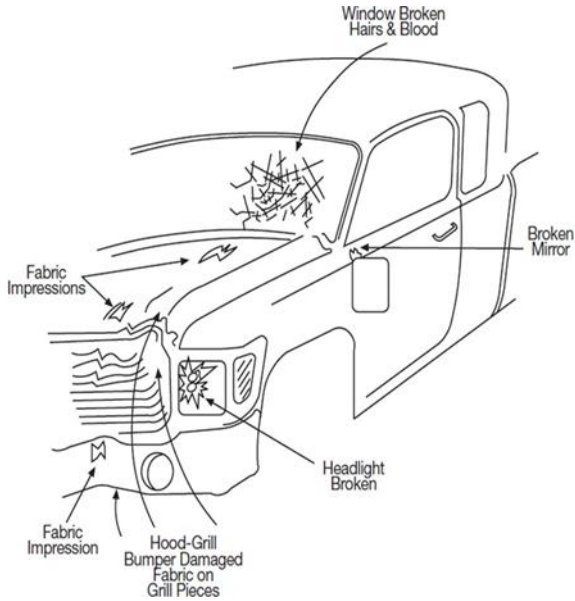

Fig. 22-3 Perspective sketch of a vehicle suspected in a hit-and-run accident. Sketch illustrates vehicle damage and locations of trace material and other evidence.

Chapter 23

Toxicology

Forensic toxicology testing is requested in many situations. These situations routinely involve testing for foreign substances (alcohol, drugs and toxins) in biological specimens. Since there is no single test that can detect all alcohol, drugs and toxins, a systematic approach is used in each laboratory to focus on the substances deemed appropriate for that particular case.

Some areas of forensic toxicology are highly standardized (e.g., blood alcohol and employment urine drug testing) and others less so. Because each laboratory is set up a little differently and pharmaceutical companies are constantly adding new drugs to the long list of available compounds, the investigator is encouraged to inquire about their toxicology laboratory's ability to detect a particular drug or toxin of interest.

Caution: Observe protocols relating to the collection of evidence.

I. Choice of Specimens

Blood and urine are the most analyzed specimens in toxicology. More information regarding drug and alcohol levels can be found in these two specimens than in any others. Toxicology results from these specimens provide the strongest basis for the interpretation of effects and exposure.

NOTE: In living individuals the concentrations of drugs in these fluids are constantly changing depending upon the relationship between the time of dosing and the time of sample collection.

Blood Samples

Blood/serum/plasma samples are the specimen of choice for investigations dealing with the effects of alcohol and drugs on an individual's functioning and behavior. The primary example of this is a blood sample drawn for alcohol determination.

Doctors and toxicologists measure blood drug concentrations because they show the best correlation to the effects on an individual. Drug companies analyze these concentrations as part of their studies to determine "therapeutic" levels prior to releasing new drugs to market. These published living studies along with those cataloging blood levels associated with toxicity and death are of prime importance for a toxicologist's interpretations of a drug's effects.

Even when an accurate blood level of a drug is obtained, the interpretation of its effects—the impairment and toxicity of the drug on a particular individual—should be done with caution. Factors that can complicate such interpretations are:

- tolerance levels
- multiple drug interactions
- biological variation
- post-mortem redistribution

Urine Samples

Drugs in urine samples can be detectable for days and concentrations can be many times higher than those in associated blood samples. *Because of this longer detection window and higher drug concentrations, urine samples are a better choice than blood samples for investigations seeking to answer the question of drug use or exposure.* Examples of investigations where urine samples should be collected are cases involving

drug use (e.g., bail jumping cases) and drug facilitated sexual assaults.

Urine drug levels show poor correlation to drug effects and therefore published therapeutic/toxic ranges for urine are rare. Urine alcohol levels are a notable exception because, if properly collected, they can be related back to the associated blood alcohol levels.

Detection Period

One of the most common questions asked of a toxicologist is "how long can drug X be detected in a person's system?" This depends on a number of factors including but not limited to:

- the size of the dose
- the size of the individual
- the natural biochemistry of that individual
- the individual's pattern of use of a particular drug
- the analytical capabilities of the laboratory (detection limits)
- the specimen being analyzed

As a general rule, most laboratories will not detect drugs in blood if the blood is collected more than 24 hours after the last ingestion/exposure. Of course, there are exceptions to this rule with some drugs/metabolites exceeding this limit and others becoming undetectable prior to this limit. When collecting urine for drug facilitated sexual assaults, specimens should be collected up to 5 days after the ingestion/exposure.

See Table 23-1 for comparison of **detection windows** for selected drugs/metabolites in blood verses urine. In general terms, drugs are detected in blood on the scale of hours while they are detected in urine on the scale of days.

Table 23-1
Estimated Detection Periods for Selected Drugs in
Blood and Urine

DRUG/METABOLITE	BLOOD	URINE
Cocaine	2-8 hours	0.5-1 day
Cocaine Metabolite (Benzoylecgonine)	20-36 hours	1-3 days
Heroin Metabolite (6-Monoacetylmorphine)	30 minutes-2 hours	<8 hours
Heroin Metabolite (Morphine)	4-12 hours	2-4 days
Marijuana active chemical (THC)	2-6 hours (Infrequent user) Longer for heavy users	≤ 1 day (If detectable at all)
Marijuana Metabolite (11-nor-9-Carboxy-THC)	12-72 hours	2-7 days (casual use) 28 days (heavy use)
Methamphetamine	4-24 hours	2-4 days
GHB	≤ 6 hours	≤ 12 hours
Rohypnol Metabolite (7-AminoFlunitrazepam)	≤ 8 hours	2-3 days
Ketamine	12-24 hours	1-2 days

NOTE: These detection periods will vary depending on an individual's drug use pattern, the specific user and the analytical capabilities/settings of the laboratory.

II. Collection of Specimens - Living Individuals

Blood Samples

Blood samples from living individuals must be drawn by a person qualified to perform phlebotomy (phlebotomist, nurse, medical technologist, etc.). The directions given below are directed primarily toward these medical professionals, but law enforcement personnel can also benefit from this information.

For blood alcohol determinations, the skin at the collection site should be cleaned with techniques that avoid solutions containing ethanol. It is highly recommended to use a non-ethanol antiseptic towelette (benzalkonium chloride or povidone-iodine) for this sterilization step. Collect the specimen according to the institution's protocol.

Fifteen to twenty milliliters of blood should be collected in gray-topped tubes (it is advised that each tube be completely filled whenever possible). These tubes contain sodium fluoride as a preservative and potassium oxalate as an anticoagulant. Lavender topped EDTA tubes can be substituted if necessary. Each collection tube should be labeled with the following information:

- the subject's name
- the date/time of collection

The tubes and the proximal container should be sealed to prevent unauthorized opening. Best practice is to seal **both** the individual tubes and the proximal container. This can be accomplished with the use of seal strips or evidence tape placed over the top of the tube and around the proximal container and initialing across the boundary between the tape and the tube/container.

Complete a specimen submission form (Wisconsin State Laboratory of Hygiene (WSLH) Blood and Urine Analysis form sections A-E, Drug Facilitated Sexual Assault-Blood and Urine Specimen Collection Kit form) or provide the hospital's laboratory specimen distribution form.

Urine Samples

When urine samples are collected for forensic purposes, the donor may be motivated to submit a false (clean) sample. In this situation, the urination should be observed by authorized personnel. Common ways to falsify a urine sample include dilution with tap or toilet water or by substituting clean, purchased urine for one's own urine. This can even be done through the use of an anatomically correct apparatus.

Twenty or more milliliters of urine should be collected in plastic specimen cup that are manufactured for this purpose (see your local hospital) or in a pristine glass screw-top jar. After the urine is collected, the lid should be tightened, or the urine may be transferred into gray-topped tubes and the container/tubes sealed with a seal strip/evidence tape. The collector/witness should place their initials across the boundary between the seal and the container. The container should be labeled with the following information:

- the subject's name
- the date/time of collection

If the urine sample is to be transported, the primary container should be sealed in a plastic bag to retain any liquid that might leak. If done properly, this plastic bag can be a secondary evidence seal which will allow any leaked urine to still be analyzed if necessary. The person sealing this plastic bag should initial the seal. Do not place any paperwork inside this plastic bag in the event of a leak.

Other Toxicology Samples

For other types of toxicology samples, follow the directions above for urine samples.

III. Collection of Specimens - Deceased Individuals

For deceased individuals, an autopsy is often warranted at which time samples for toxicology should be collected. The selection of toxicology samples in postmortem cases can vary; however, some samples are of primary importance. A tiered approach is used here.

Tier One: Primary Specimens

Blood: Collect 20 or more milliliters of blood in purple and red topped tubes. As with living persons, blood is the primary specimen for postmortem toxicology. The preferred sample is a peripheral one (iliac or femoral). If that isn't available or in addition to that source, the preference is for cardiac or subclavian. Samples to substitute for blood can include spleen, bile and liver (see below).

Urine: Collect 15 or more milliliters of urine in a clean glass jar, a urine specimen cup with no preservative or a red-topped tube. Urine is a valuable specimen for the same reasons as discussed for living people. Urine alcohol levels can also be useful in decomposition cases to interpret the neo-formation of ethanol. Samples to substitute for urine include bile, liver and kidney (see below).

Vitreous humor (eye fluid): Collect all vitreous fluid from both eyes in a red top tube. Vitreous fluid is useful for the interpretation of blood alcohol in cases of decomposition or trauma and can be related back to the associated blood alcohol level. This fluid can also be

used to some degree as a replacement for peripheral blood.

Stomach contents: Collect the entire contents or a **measured** portion in a clean glass jar. Stomach contents can be used to determine the amount of drug taken by an individual just prior to death. This analysis can be helpful in determining suicidal intention. For accurate analysis, the toxicologist must be informed of the full volume if only a portion of the stomach contents is submitted or if the contents were picked through for tablets or unknown material as this will falsely elevate the results if the full contents aren't submitted.

Ante-mortem blood/serum/urine samples collected upon admission to the hospital: These samples are very important in cases where the individual survived for a significant period of time in a hospital prior to death and can be used in lieu of postmortem specimens. **Always ask for all samples!**

Tier Two: Replacement/Additional Specimens

Spleen samples: A representative sample (approximately 10-20 grams) in a clean glass jar or specimen cup. The spleen is a blood rich organ which can be used in lieu of liquid blood.

Bile samples: 5-10 milliliters in a gray topped tube. Bile samples contain high drug concentrations and can be used in lieu of urine samples to screen for toxic substances.

Liver samples: A representative sample (approximately 50 grams) in a clean glass jar or specimen cup. Liver samples can be useful in cases of postmortem redistribution (see peripheral blood above) and extreme decomposition.

Tier Three: Specialty Samples

Hair samples: Collect a large sample at least one-half inch diameter lock of 3-inch-long head hair containing the bulb (pulled not cut) for toxicology work. The Hair samples show historic drug use but are not useful for acute poisoning cases. The Wisconsin State Crime Laboratory does not currently analyze hair samples for drugs.

Lungs: Lungs can be collected in an airtight container (clean paint can) if solvent inhalation is suspected immediately prior to death. The gaseous headspace above the organ can be sampled for analysis of volatiles. Blood is also useful in these cases so long as it is in a secure preserved tube.

IV. Specimen Storage and Shipping

All toxicology specimens should be stored in a refrigerator.

If specimens are to be sent through the mail, follow the U. S. Postal Service regulations regarding shipment of biohazardous evidence. Biological samples sent through the mail must be packaged in the following manner:

- The sample must be **triple packaged** in a primary leak-proof receptacle (tubes), a secondary container (plastic biohazard bag) and a rigid outer shipping container (cardboard/styrofoam box).
- The secondary container (plastic bag) must be sealed and marked with a biohazard sticker.
- The secondary container must have absorbent cushioning if the primary container should leak or break.

For the most current information regarding packaging, see U. S. Postal Service, Domestic Mail Manual at www.USPS.com or IATA Packing Instruction 650.

V. Toxicology Testing

Toxicology testing can be as routine as a single blood alcohol test or as complex as the quantitation of numerous drugs in multiple samples. The level of testing required generally depends upon the type of case and the charges pending. For the Wisconsin State Crime Laboratory, a general outline of testing is listed below. Review the Toxicology Evidence Submission Guidelines at <https://www.doj.state.wi.us/dfs/chemistry/forensic-toxicology>.

Blood Alcohol

Felony operating while intoxicated cases (OWI), non-traffic related crimes such as bail jumping, reckless use of a weapon, intoxicated use of a firearm and endangering safety often involve only volatiles testing. If the blood alcohol level is 0.10% and above, further drug analysis will be canceled. Generally, alcohol has the predominant effect over other drugs that may be present and is well suited to support these charges. The exceptions are homicides, sexual assaults, and special circumstances (please contact a WSCL Chemistry Supervisor or Forensic Case Manager to discuss).

Drug Screening and Confirmation

Drug screening and confirmation are the next level of toxicology testing for blood and urine samples. Immunoassay screening for a routine panel of drugs is usually performed first. Any immunoassay positives are followed by gas chromatography/mass spectrometry (GC/MS) or liquid chromatography/mass spectrometry/mass spectrometry (LCMSMS) confirmation. The current immunoassay panel includes:

- amphetamine

- methamphetamine
- cocaine/metabolite
- opiates (e.g., codeine, morphine, hydrocodone, hydromorphone, oxycodone, heroin metabolite 6-MAM),
- benzodiazepines (e.g., diazepam, alprazolam, clonazepam, lorazepam, flunitrazepam, etizolam)
- cannabinoids (marijuana)
- fentanyl
- buprenorphine
- ketamine
- zolpidem

Samples can also be analyzed using a GC/MS general drug analysis. This drug analysis detects a broad spectrum of acidic, basic and neutral drugs including over 150 pharmaceutical compounds.

Additional Testing

Additional tests are available and are utilized as needed or requested. These include:

- GHB (gamma-hydroxybutyrate) which is routine for drug facilitated sexual assault cases
- NSAIDs (e.g., Acetaminophen, Salicylic Acid)

Please inquire about additional testing if necessary

Communication between the Crime Lab and the submitter is important to insure the proper level of testing.

VI. Laboratory Choices: Hygiene Lab vs. Crime Lab

The State of Wisconsin has two independent FORENSIC TOXICOLOGY laboratory systems. One is the Wisconsin State Crime Laboratory which is part of the Wisconsin Department of Forensic Sciences and Department of Justice, and the other is the Wisconsin State Laboratory of Hygiene (WSLH) which is part of the University of

Wisconsin System. For animal toxicology cases contact the Wisconsin Veterinary Diagnostics Laboratory (see contact information below).

The submitter should select the correct laboratory prior to mailing. Valuable time is lost, and the chain of custody is extended when specimens are sent to the wrong laboratory. It is also required to include a completed Transmittal of Evidence Form when WSLH kits are submitted to the Crime Lab.

In addition to death investigation testing, the WSLH will provide traffic safety and other motor vehicle matters testing for law enforcement agencies. By statute, the Crime Laboratories are only required to accept cases involving a felony or a potential felony. The Crime Laboratories will make all efforts to accommodate the needs of law enforcement. Please contact your local Crime Laboratory to inquire about analysis of evidence related to non-felony offenses.

VII. Toxicology Laboratory Contact Information

The Crime Laboratories in Madison and Milwaukee both have full Toxicology Units; the Crime Laboratory in Wausau has a Blood Alcohol Unit. The Madison Laboratory completes toxicology drug analysis on biological samples submitted by agencies in the Wausau service area. The addresses and phone numbers are listed in the Introduction.

The WSLH can be contacted at
Wisconsin State Laboratory of Hygiene (WSLH)
2601 Agriculture Drive, P.O. Box 7996,
Madison, WI 53707-7996
(608) 224-6241
<http://www.slh.wisc.edu/forensic/>

Contact information for the Wisconsin Veterinary Diagnostics Laboratory can be found at <http://www.wvdl.wisc.edu>.

In addition to the state laboratories there are also independent laboratories which are approved to analyze blood and urine specimens for alcohol under Wisconsin Statute 343.305(6)(a). A list of all approved laboratories can be found at http://dhs.wisconsin.gov/rl_DSL/Labs/LABSintro.htm or by calling the Wisconsin Department of Health and Family Services, Division of Supportive Living, Clinical Laboratory Unit at (608) 267-9862.

VIII. Toxicology Kits

The WSLH provides blood and urine collection kits intended for forensic toxicology impaired driving offenses and are free of charge for these purposes. See above for their contact information.

Medical-Forensic DFSA Kits are available free of charge to law enforcement from Document Sales for the collection of toxicology (blood and urine) samples from sexual assaults.

More information can be found here: <https://www.doj.state.wi.us/dfs/chemistry/forensic-toxicology>

IX. Contacting the Toxicology Unit

Communication between the Toxicology Unit and the submitting agency is important to ensure the proper level of testing. DRE officers should also send their face sheets to the appropriate laboratory receiving the sample. Please convey any relevant information about your case on the Transmittal of Evidence or by emailing toxicology@doj.state.wi.us or by calling the Crime Laboratory in your service area.

Chapter 24

Controlled Substances

Forensic Scientists in the Controlled Substances Unit detect and analyze controlled substances and other drugs in plant materials, powders, liquids, capsules, tablets, cigarettes (joints), cigars (blunts) and many types of paraphernalia such as scales, spoons, straws and smoking devices. They also assist agents from the Division of Criminal Investigation (DCI) in assessing, processing and collecting evidence at clandestine drug laboratories.

I. Submission of Drug Evidence

Proper collection, packaging, storage and submission of drug evidence help ensure the integrity of the evidence for forensic analysis. Each type of evidence requires specific handling precautions that need to be followed when submitting drug evidence to the laboratory for analysis. Please also refer to the [Controlled Substances Section](#) on the DFS website for additional information regarding submission guidelines, FAQ, and other pertinent information. There are different types of drugs in many forms. Some of the commonly seen types are listed below.

Marijuana

The most common plant material submitted to the Laboratory for analysis is Cannabis. Cannabis contains a group of related compounds referred to as cannabinoids. The most notable psychoactive cannabinoid is delta-9-THC (commonly known as THC) and generally the main cannabinoid in marijuana while a non-psychoactive cannabinoid, Cannabidiol (commonly known as CBD) is generally the main cannabinoid in hemp. The amount of THC present is the main determinant in classifying Cannabis as hemp or marijuana as defined in the Wisconsin Statutes

(Chapter 94 and 961). Hemp and marijuana cannot be distinguished by physical appearance, odor, or the Duquenois-Levine color test. However, the 4-Aminophenol (4-AP or cannabis typification) color test may assist in distinguishing between hemp and marijuana and should be used in addition to the Duquenois-Levine test. The WSCL does not perform a quantitative analysis for the amount of THC present, however, the analytical scheme used can assess the ratio of THC and CBD present and provide information to law enforcement regarding whether the plant material is consistent with marijuana or hemp.

For simple possession cases, the dried plant material should not be submitted to the Laboratory for a chemical analysis until a trial date has been set. Associated paraphernalia such as pipes, cigarette papers and roaches often found with suspected plant material should only be submitted to the Laboratory if they are essential to the case. Seeds do not contain THC and should not be submitted for analysis.

Vape cartridges should not be submitted unless imperative to the case. When there are multiple cartridges of similar brands or types, limit submission to one of each type. Weights will not be reported for vape cartridges.



Fig. 24-1 Marijuana in PVC Pipes



Fig. 24-2 Marijuana Bes



Fig. 24-3 Brick of Hash

Fresh plant material such as recently harvested marijuana plants needs to be dried prior to packaging or packaged in breathable containers such as brown paper bags to allow the material to dry safely. If fresh or wet plant material is packaged in airtight containers such as plastic bags, it will rot fairly rapidly like wet silage, forming a soft, watery mass with a foul pungent odor. In addition, the material can become moldy. Moldy plant material is a **potential health risk**. The time to **dry plant material is immediately upon confiscation**. If your agency confiscates fresh plant material, the following should be done:

1. Air dry the material in a well-ventilated, secure area until thoroughly dry.
2. After obtaining the weight of the evidence, take representative samples of the **dried** plant material from each batch (container, package,

etc.) and seal them for transmittal to the Laboratory. A few grams of material from each item are sufficient for analysis.

3. Package the dried plant material in a sealed paper bag or envelope to further reduce the possibility of spoilage.
4. In order to be counted as a plant, there must be intact leaves, stems, and roots. If the plant count and analysis is important to the case, plants must be packaged separately.



Fig. 24-4 Bundles of Khat

Khat is plant material that is native to eastern countries of Northern Africa. Khat is usually seen as tied bundles which consist of plant shoots with green leaves wrapped in a large plant leaf. Khat contains two controlled substances, cathinone and cathine. Without the proper preservation, cathinone (Schedule I) will break down into cathine (Schedule IV). **To help prevent this breakdown and preserve the material, khat should be frozen soon after confiscation.**

Other Plant Material

Other plant materials containing controlled substances may also be encountered. Common examples are peyote cactus that contains mescaline, psilocybin mushrooms and opium poppies. Plant material of this nature may be submitted to the Laboratory for analysis anytime after the plant material has been thoroughly

dried. Additionally, synthetic cannabinoids sold in a variety of herbal products such as “K2”, “Kush”, and “Mr. Smiley” have been seen. Due to the continually changing components in these products, they should be submitted to the Laboratory for analysis.



Fig. 24-5 Peyote Buttons (Mescaline)



Fig. 24-6 Psilocybin Mushrooms



Fig. 24-7 Opium Poppies

Powders and Chunky Material

Cocaine, cocaine base (crack) and heroin are controlled substances usually seen in a powdered or chunky form. These drugs are commonly encountered in colors ranging from white to off-white, or tan to brown. Cocaine is sometimes seen as compressed bricks of white to off-white powder (kilo bricks), with logo marking and multiple layers of tape and plastic packaging.

Other substances that may be seen as powders, chunks, or crystalline material include controlled substances such as methamphetamine, MDMA, and ketamine. Additionally, synthetic cathinones commonly referred to as "bath salts" have been seen. These synthetic cathinones have previously been marketed in a variety of products such as "Ivory Wave", "Vanilla Sky" and "Cloud Nine" and were sold as bath salts, plant food, or jewelry cleaner with labeling including "not for human consumption". Due to the continually changing components in these products, they should be submitted to the Laboratory for analysis.

Recently fentanyl and fentanyl analogs have also be seen in a powdered or chunky form. These compounds are very potent opioids. Law enforcement personnel should always take precautions to minimize their exposure to any drug evidence, but due to the potency of fentanyl compounds, special precautions are necessary. This includes wearing proper personnel protective equipment (PPE) and ensuring evidence is properly contained. When handling suspected fentanyl compounds, at a minimum, basic PPE should include nitrile gloves, N95 dust masks, and eye protection. Higher levels of PPE may be needed depending on the potential for exposure. Avoid any activity or task that would cause powder material to become airborne. Personnel should also be trained to recognize symptoms of opiate toxicity and be able to administer

Narcan® if necessary. Items suspected to contain fentanyl or fentanyl analogs should be labeled with an appropriate hazard label to alert others of potential hazards.

Upon seizing the evidence, the officer should perform the appropriate color test(s) for the suspected material (see Section II, Color Testing below). If the confiscated evidence is in trace or residual amounts, avoid conducting any color tests; submit the items directly to the Laboratory if analysis is necessary. If agencies need access to a ventilated hood to safely perform color tests, they may schedule an appointment to come to WSCL.

Liquids

Phencyclidine (PCP), Gamma-Hydroxybutyric Acid (GHB), Gamma-Butyrolactone (GBL), 1,4-Butanediol and anabolic steroids are controlled substances usually seen in liquid form. Steroids usually are available in pharmaceutical preparations with labels often in a foreign language. Never place liquids directly into metal cans, pill bottles, or plastic bags. Use a container appropriate for liquids such as glass bottles or specimen jars. These should also be further contained with secondary packaging such as Nalgene bottles to prevent breakage and/or leakage.



Fig. 24-8 Steroids



Fig. 24-9 Liquid PCP

Pharmaceuticals

Pharmaceutical tablets, capsules and patches which are seized can frequently be identified through their markings (imprint codes). These tablets are well defined and marked. An officer should consult references such as the Physicians' Desk Reference, Drug Identification Bible, Drugs.com, to determine if the evidence is a controlled pharmaceutical preparation. The markings on the suspected pharmaceutical tablets must compare thoroughly to a reference picture or description before making any conclusion. Alternate sources of information about marked tablets, capsules and patches are include area pharmacists, local or regional poison control centers. Pharmaceuticals which are not controlled under Wisconsin Statute Chapter 961 should not be submitted to the laboratory

Counterfeit Tablets

In recent years, counterfeit tablets have become increasingly common. Counterfeit tablets are illegally manufactured tablets that appear to be legitimate pharmaceutical preparations. Counterfeits may contain controlled substances, designer drugs, and other components inconsistent with the pharmaceutical identification. They also may not contain any active ingredient. A common counterfeit tablet seen currently is a tablet which resembles the 30 mg Oxycodone tablet (see Fig. 24-10 below) but actually contains

fentanyl. Other commonly seen counterfeits resemble preparations containing alprazolam (Xanax®).



Fig. 24-10 Illicit Tablets



Fig. 24-11 Illicit tablets submitted as 'Ecstasy'

Illicit tablets often contain many types of controlled substances, and these appear in many colors and logos. Illicit tablets have traditionally contained MDMA. However, laboratory analysis of these tablets now primarily identifies methamphetamine. This may be in combination with other controlled substances such as eutylone or N-ethylpentylone or other adulterants such as caffeine. It is recommended that officers submit illicit tablets to the Laboratory for analysis to determine the specific controlled substance(s) present.

Syringes and Other Sharps

Because of the dangers for contracting bloodborne diseases through an exposure to a contaminated needle or syringe which has been used for injecting drugs, extreme caution needs to be exercised when handling,

packaging, storing and submitting these items as evidence. **DO NOT SUBMIT** syringes or needles to the Crime Laboratory for analysis **unless absolutely necessary**. If syringes, needles, razor blades or any other sharp items are to be submitted to the Crime Laboratory, be sure to handle them with **extreme care** and to package them in sealed **puncture proof and biohazard labeled** containers.

II. Color Testing

Color test pouches are available from commercial suppliers that provide drug investigators with preliminary information regarding the nature of a suspected controlled substance. The tests results are presumptive. Although the test results, when performed by an officer in the field, are not sufficient to serve at trial as definitive identification of a controlled substance, they often will suffice for probable cause at the preliminary hearing. In many instances, the color testing results can be used to obtain search and arrest warrants. Therefore, it is crucial that these tests always be performed according to the manufacturer's instructions.

In cases where only small amounts of material are present, **never use more than of the material for the test**. If there is not enough material to run the test, skip the color test and submit the item to the Laboratory for analysis. **DO NOT send the used plastic pouches containing the results of color tests to the Laboratory with the evidence. These pouches contain chemicals that may leak and contaminate your evidence.** Used pouches should be disposed of according to the manufacturer's instructions.

III. Pseudo Drugs

The State Crime Laboratory in Milwaukee supplies pseudo- cocaine and pseudo-heroin used in narcotic canine training. The pseudo drugs are available in pound and half pound sizes only. Agencies interested in obtaining pseudo drugs need to request in writing on official letterhead the following:

1. The type and quantity of the pseudo drug needed.
2. The date by which the material is needed. (If possible, no less than ten working days).
3. The name and phone number of the contact person and the billing address of the agency making the request.
4. The shipping address if the items are to be sent via FedEx or UPS.

Send the request to the following address:

WI State Crime Laboratory
Attn: Chemistry Supervisor
1578 S. 11th Street
Milwaukee, WI 53204

Chapter 25

Arson

Many times, it is difficult to ascertain whether a fire was accidental or arson. This is especially true when simple ignition devices such as a match and paper were used to start the fire. Frequently flammable liquids such as gasoline, oil, fuel oil, charcoal lighter fluid, etc., are used as accelerants. If used, and if the fire origin can be determined, it may be possible to detect and classify ignitable liquids.

*The Laboratory is equipped with sensitive instruments capable of detecting and classifying trace quantities of volatile substances. Detection is not possible if the fire completely consumes the ignitable liquid or if the samples are not collected from the correct location. Because flammable liquids readily evaporate, great care must be taken in the collection and packaging of fire debris suspected of containing them. Containers of arson evidence need to be airtight to prevent loss by evaporation, and possible contamination. Moisture is not a problem. **Do not air-dry arson evidence.***

Caution: Observe laws relating to the collection of evidence.

In considering whether or not a fire is a case of arson, review the possible motives (financial gain, personal satisfaction, concealment of another crime, revenge or pyromania). The following is a brief general procedural guide for use in investigation of suspected arson cases. It is recommended that someone who has specialized training in fire investigation conduct the fire scene investigation.

I. Procedure at Crime Scene

- A. Note (and photograph to scale whenever applicable):
 - a. Condition of all locks, doors, windows. If entry has been forced, *see Chapter 13 - Burglary and Chapter 14 - Building Materials*.
 - b. Origin of fire (one or many sites?).
 - c. Identification of igniting material (foreign to the scene?).
 - d. Presence of flammable liquids by:
 - i. odor of petroleum products, paint solvents, alcohol, etc.
 - ii. stains on floor or other material
 - iii. evidence of explosions not due to heat (shattered glass)
 - iv. unusual burning patterns (splashed areas or trailers)
 - v. rapid spread of fire not explainable by structure, weather, or other conditions
 - vi. smoke not explainable by building materials
 - vii. characteristic heavy soot
 - viii. unusual flame coloration
 - e. Evidence of another crime which the fire might conceal (items stolen, evidence of violence).
 - f. Recent similar fires in the vicinity (date, time, location, intended victim).
- B. Collect in separate, airtight containers (e.g., half-pint through five-gallon new, unused, metal paint cans):
 - a. All igniting devices (fuses, candles, wicks, trailers, rags, etc.).
 - b. Charred debris and related material from the origin where the accelerant was placed (container should be one-half to three-quarters full).

- c. Samples of plaster, upholstery, wood or other substances that may have been penetrated by ignitable liquids. Any fresh stains should be collected.
 - d. Samples of soil (two to three quarts) which may have been saturated by ignitable liquids (container should be three-quarters full). Soil samples need to be refrigerated or frozen to prevent microbial degradation of volatiles.
 - e. Any trace evidence left by the arsonist such as hair, clothing, fibers, blood stains, fingerprints, etc. (For proper collection procedure see chapter pertaining to that specific type of evidence.)
 - f. Any and all tools or pieces of metal at the scene that will be examined for DNA or fingerprints (airtight container not necessary).
 - g. Small amounts of ignitable liquids should be collected in airtight clean glass vials or bottle sealed or absorbed with cotton balls, swabs or gauze and placed in an airtight container.
 - h. When fire debris consists of carpeting, cloth, plastics, polymers, synthetics or other material, uncontaminated known samples should be collected separately and submitted as comparison samples. Comparison samples allow the scientist to distinguish between natural or fire produced artifacts and ignitable liquids.
- C. If a container is found that has a flammable label on it and is suspected of being involved in the fire, a sample of the liquid should be submitted, or a container of the same labeling should be purchased from an area store and submitted to the Laboratory. If unavailable, send in the description of the flammable contents from the label.

- D. In cases involving large volumes of flammable liquids or suspected flammable liquids, contact the Laboratory for the proper procedures in handling and packaging.

II. Suspects

Incidental to arrest, with consent, with a search warrant, or with a combination of the above, obtain the following:

- A. Ignitable liquids, tools or starting devices in the suspect's car and home that can be used to associate a suspect with the fire. Submit fire starting devices **only** after they have been deactivated and properly packaged.
- B. Clothing worn at the time of the crime (if collected within a reasonable amount of time), including shoes. (Package in clean, unused airtight paint cans or specifically made nylon fire debris bag).
- C. Any trace evidence (paint, glass, building materials, etc.) which might connect the suspect to the scene found on the suspect's clothing or in the suspect's car or home.



Fig. 25-1 New, clean paint cans make ideal containers for preserving evidence suspected of containing

ignitable liquids. Cans are available from paint stores or wholesalers.



Fig. 25-2 The area where the ignitable liquid is in contact leaves a pattern that is different from surrounding areas. Door propped open, holes chopped in floors, "trailer" used to direct the fire from one area to another, etc., are all reasons to suspect that a fire is due to arson.

An index is not included in the print copy. To keyword search the Evidence Handbook, use the online version.

One method to keyword search that has proven successful is Ctrl+F. By pressing ctrl and F together on the keyboard a field will appear that provides opportunity to type in a word (or phrase) to search.

**EVIDENCE
EVIDENCE**

**EVIDENCE
EVIDENCE**



**EVIDENCE
EVIDENCE**

**EVIDENCE
EVIDENCE**